

APPENDIX 7

BIODIVERSITY

LIST OF CONTENTS

- APPENDIX 7-1. WINTER HABITAT STUDY, TYMON AND BANCROFT PARKS,
ROUGHAN O'DONOVAN, JUNE 2018
- APPENDIX 7-2. PODDLE RIVER – ECOLOGICAL REPORTS RELATING TO THE PODDLE
RIVER FLOOD ALLEVIATION MEASURES, MAMMAL, BIRD AND
BOTANICAL REPORTS, BRIAN KEELEY AND MALGORZATA GOSKA
WILKOWSKA, 03-10-2018
- APPENDIX 7-3. DESKTOP RECORDS OF RARE AND PROTECTED SPECIES
- APPENDIX 7-4. INFORMATION ON THE CONSTRUCTION AND BENEFITS OF
ARTIFICIAL NESTING PLATFORMS

**APPENDIX 7-1. WINTER HABITAT STUDY, TYMON AND BANCROFT PARKS,
ROUGHAN O'DONOVAN, JUNE 2018**



Winter Habitat Study Tymon and Bancroft Parks

CONFIDENTIAL

.....
FINAL | JUNE 2018
.....

Winter Habitat Study of Bancroft and Tymon Parks

TABLE OF CONTENTS

1. INTRODUCTION	3
1.1 Background	3
1.2 Approach and Objectives	3
1.3 Objectives of the Study	3
1.4 Existing Land Use	4
1.5 Description of the preferred Flood Risk Management Option (Option 2)	4
2. METHODOLOGY	5
2.1 Scope of the Assessment	5
2.2 Desk Study	5
2.3 Specific Ecological Methodologies	5
2.3.1 <i>Habitat Survey</i>	5
2.3.2 <i>Badger Survey</i>	5
2.3.3 <i>Otter Survey</i>	6
2.3.4 <i>Wintering Bird Survey</i>	7
3. RESULTS	9
3.1 Desk Study	9
3.2 Field Surveys	10
3.2.1 <i>Habitats</i>	10
3.2.2 <i>Otter Survey</i>	12
3.2.3 <i>Badger Survey</i>	12
3.2.4 <i>Wintering Bird Survey</i>	14
3.2.5 <i>Invasive Species</i>	17
3.2.6 <i>Other Species</i>	18
4. DISCUSSION	19
4.1 Badger	19
4.2 Otter	19
4.3 Wintering Birds	19
4.4 Invasive Species	19
5. RECOMMENDATIONS	20
5.1 Badgers	20
5.2 Otter	20
5.3 Invasive Species	20

5.4	Wintering Birds	20
5.5	Water Quality	20
6.	ECOLOGICAL ENHANCEMENTS.....	22
6.1	Woodland thinning	22
6.2	Rejuvenation of the River Poddle.....	22
6.3	Bat Boxes and Bird Boxes	22
6.4	Removal of Non-native Plants.....	22
7.	CONCLUSION.....	23
8.	REFERENCES	24

Appendix A Mapping

Appendix B Bird Sectors

Appendix C Bird Counts

1. INTRODUCTION

1.1 Background

Roughan & O'Donovan was appointed by South Dublin County Council to undertake a Winter Habitat Study of Bancroft and Tymon Parks in County Dublin. The parks are connected by the River Poddle, which enters Bancroft Park from the west and flows into the western section of Tymon Park where it follows an artificial course through a series of ponds before passing under the M50 and emerging in the eastern section of Tymon Park. It flows through a number of ponds before exiting the park at Wellington Road. The parks serve as a local amenity and contains amenity grassland, woodland and ponds. The former land use of the site was agricultural, and a series of hedgerows show the former field boundaries.

The Poddle catchment is within the Eastern CFRAM study area. Due to the risk of flooding, the Poddle catchment was prioritised for flood alleviation works. To this end, the Poddle Options Report was produced in 2014. The report identified a preferred option for reducing the risk of flooding in the Poddle catchment, which consists of a number of embankments and flood walls. The flood alleviation measures are likely to involve the creation of 2 m high embankments and an overflow weir at the ponds in Tymon Park as well as 1.5 km of flood walls along the river downstream of Tymon Park. The purpose of the embankments and overflow weir is to increase the capacity of the ponds in order to use them for flood attenuation.

The purpose of this study is to identify and quantify the populations of otter, badger and wintering birds in Tymon and Bancroft Parks and to determine the impact, if any, that the flood alleviation works may have on them. This report is based on the results of the survey work undertaken between January and mid-April 2018.

The surveys were undertaken between January and April 2018 and were carried out by Patrick O'Shea MSc ACIEEM and Mike Bailey MSc MCIEEM.

1.2 Approach and Objectives

For the purposes of this Ecological Study, habitats, otter, badger and wintering birds were examined as features of ecological significance and were classified as Key Ecological Receptors (KERs). These KERs are all known to occur within Bancroft and Tymon Parks.

This study quantifies the potential impacts on the KERs and identifies the mitigation measures required to avoid and reduce any likely significant impacts. The results of the ecological surveys informed the recommendations, thereby addressing potential impacts on habitats and species.

The Study began with a Desk Study and consultation process aimed at gathering relevant information on the ecological conditions in Bancroft and Tymon Parks.

Following the desk study, a multidisciplinary ecological walkover survey was conducted in Bancroft and Tymon Parks adhering to *Ecological Survey Techniques for Protected Flora and Fauna during the Planning of National Road Schemes* (TII, 2008a) and *Best Practice Guidance for Habitat Survey and Mapping* (Smith *et al.*, 2011). The habitat survey classified habitats according to *A Guide to Habitats in Ireland* (Fossitt, 2000). The findings of these habitat surveys are presented in Appendix A. As part of the walkover survey, evidence of badger, otter and invasive species was also recorded.

Using the comprehensive assessment of the existing environment (baseline conditions), it has been possible to accurately predict the likely impacts of the proposed flood alleviation measures on the KERs and correctly assign an ecological significance to them.

1.3 Objectives of the Study

The overall objective of this study was to identify key habitats and species in order to assess and prioritise these animals on the site. The scope of the study was the collection of material

to enable the proper design and detail for any proposed flood alleviation measures. The main objectives were to:

1. Identify and assess the presence, numbers and status of badger and identify their foraging routes and sites and locations of setts.
2. Identify and assess the presence, numbers and status of otter, and identify their foraging routes and sites and locations of holts.
3. Identify and assess the presence of over-wintering birds (particularly Brent Geese) inhabiting and using the biodiversity resources on the site.
4. Identify potential impacts of construction processes, the effects of flooding the areas and recommend appropriate mitigation measures to minimise impact.
5. Identify, categorise and map the type of habitat of particular importance to the species being surveyed. Map the extent of the habitat type in each case.
6. Propose detailed mitigation measures, including avoidance of some elements if deemed necessary.
7. Recommend future habitat management and ecological monitoring of the site.

1.4 Existing Land Use

Tymon Park is a 130 ha park, catering for a range of recreational activities such as walking and field sports. The park contains playing fields, managed grassland for biodiversity, woodland, ponds and paths. The woodlands are generally young (5-7 m tall) mixed broadleaved woodland containing beech, ash, oak, sycamore, alder, birch and hazel. The River Poddle flows through Tymon Park from the west, passing through into the western section of Tymon Park where it follows an artificial course through a series of ponds before passing under the M50 and emerging on the eastern section of Tymon Park. It flows in an east-west direction passing through a series of ponds before exiting the park at Wellington Road.

Bancroft Park is an 11 ha park. It follows the course of the River Poddle between Castletymon Road and Greenhills Road. The park is predominantly amenity grassland including a playing pitch and also contains woodland along the edges and some pockets of woodland in the centre.

1.5 Description of the preferred Flood Risk Management Option (Option 2)

The preferred option (Option 2) involves creating a number of raised embankments and an overflow weir at the existing ponds in Tymon Park to create additional storage during floods (RPS, 2014). Flood walls will also be constructed between the storage area and for 2 km downstream along with measures to account for rainfall being diverted away from the River Poddle.

Additional measures will also be required downstream which would consist of flood walls and earth embankments located where the river banks are low relative to water level.

The following works are proposed:

- Storage: 280 m of sheet-piled core earthen embankment averaging 2 m in height and an overflow weir around Tymon Park ponds.
- Hard defences: 3,420 m of retaining wall and 180 m of earthen embankment.
- Sealing manholes: manholes to be sealed along main Poddle culvert line at Dolphin's Barn area and Poddle Park area.
- Culvert inlet screens.
- Flap valves.

2. METHODOLOGY

2.1 Scope of the Assessment

This section describes the methodology followed in the compilation of this study. Widely accepted and recognised guidelines were followed in relation to every aspect of the scoping, surveys, assessment and recommendations. The scope of the Study, as outlined in the RFQ document, was to include habitats, wintering birds, otter and badger.

The habitat survey followed *Best Practice Guidance for Habitat Survey and Mapping* (Smith et al., 2011) and *A Guide to Habitats in Ireland* (Fossitt, 2000). The wintering bird surveys followed *I-WeBS Counter Manual Guidelines for Irish Wetland Bird Surveys counters* (BirdWatch Ireland, 2016).

The Badger and Otter survey methodology was based on the Transport Infrastructure Ireland (formerly the National Roads Authority) guidelines:

- TII/NRA (2008b) Guidelines on the Treatment of Otters Prior to the Construction of National Road Schemes. National Roads Authority, Dublin.
- TII/NRA (2006a) Guidelines on the Treatment of Badgers Prior to the Construction of National Road Schemes. National Roads Authority, Dublin.

In addition, *Guidelines for Ecological Impact Assessment in the UK and Ireland* (CIEEM, 2016) was used to provide direction in the preparation of the scope, structure and content of the study.

2.2 Desk Study

A desktop study was carried out to collate records of wintering birds, badger and otter in Bancroft Park and Tymon Park. The following sources of information were used:

- Records from the NPWS web-mapper.
- Review of the National Biodiversity Data Centre (NBDC) web-mapper.

Statutory and non-statutory consultees were contacted in January 2018. The purpose of the consultations was to collect any useful records and observations on wintering birds, otter and badger using the parks. In addition to consultees, the Park Ranger, local bird watchers and members of the public also provided useful information, particularly in relation to Brent Geese.

2.3 Specific Ecological Methodologies

2.3.1 Habitat Survey

The habitat survey involved visiting the entire site on foot. Aerial photographs were marked up showing the areas of habitat as polygons. Lines were drawn to represent linear features such as hedgerows and ditches. Target notes were made of list species present, signs of disturbance and height of trees as required.

As part of the habitat surveys, the presence of invasive species was recorded. This included species listed on the Third Schedule to the European Communities (Birds and Natural Habitats) Regulations, 2011 (as amended). Notes on the species, location and area were recorded.

2.3.2 Badger Survey

Eurasian Badger (*Meles meles*) and their setts are protected under the Wildlife Acts, 1976-2012 and are evaluated as being Least Concern in the Irish Red Data list for mammals (Marnell et al., 2009). It is an offence to intentionally kill or injure a Badger or to wilfully interfere with or destroy the breeding site or resting place of a protected wild animal. Badgers are found throughout Ireland in areas of suitable habitat (Hayden & Harrington, 2000). The badger population in the Republic of Ireland is stable and is 84,000 (Sleeman et al., 2009).

The badger is an adaptable species inhabiting lowland grassland and woodland habitats and also occasionally in upland and suburban areas. Its group size is typically 4-5 animals (Feore, 1994; Smal, 1995). They are opportunistic foragers that exploit a broad range of prey. Earthworms are common in the diet but account for little of the bulk. Seasonally abundant food sources are important including insect larvae and frogs (Cleary et al., 2009).

The Badger survey was conducted in order to determine the presence or absence of Badger within the study area. The Badger survey involved a systematic search of all fence lines, woodland and scrub habitats for physical evidence of Badger, e.g. setts, latrines, badger paths. The optimal period for Badger surveys is during seasonal peaks in territorial activity and when vegetation cover is at a minimum (February to April and less pronounced peak in October). The study area was surveyed in January and February 2018.

Badger setts were classified as being main, annex, subsidiary or outlier setts, based on recommendations in Harris et al. (1994) and consistent with the convention set out in TII/NRA (2009b). Where badger setts were found, the number of entrances, activity level and sett status was recorded. Sett status categorisation is as follows:

- **Main sett:** Used throughout the year and constitutes the main breeding sett. Where a sett exhibits much activity and appears to be the largest (normally at least five holes) and most well used sett within a badger territory it is categorised as the main sett. Main setts always have active Badger runs leading away from them and are normally marked by latrines.
- **Annex sett:** Categorised where assumed to form a part of the main sett area but where the sett is unlikely to be directly linked by an underground passage to the main sett either due to a barrier (e.g. separated by a watercourse or ditch) or by distance. Normally linked to the main sett by a well used path and lie within 150 m of a main sett entrance.
- **Subsidiary sett:** Categorised where believed to offer an alternative large sett complex to the main sett. Subsidiary setts are normally at least 50 m away and are not always obviously linked by a well used path. Subsidiary setts often exhibit moderate levels of activity, are larger than outlier setts but smaller than main setts. Often marked by latrines.
- **Outlier sett:** Often comprise just one or two holes. Used infrequently and can be found at the edges of a Badger group's territory.
- **Disused sett:** Appears abandoned by the group for at least a year. Differs from "inactive" setts which are judged to be temporarily disused. Often completely blocked with vegetation or collapsed.

Exact locations of badger field signs and setts were marked with 10-figure grid references using a hand-held high-sensitivity Garmin GPSMAP 64st Geographical Positioning System (GPS) and imported into a geospatially referenced Geodatabase in ArcGIS.

Sett status can quickly change. It is not uncommon for badgers to switch the location of their main sett to the location of a previously identified subsidiary sett, or an outlier sett to be developed into a main sett. Motion-activated infra-red cameras were deployed on setts and in woodlands to determine the distribution and estimate the badger population.

2.3.3 Otter Survey

European Otter (*Lutra lutra*) is listed on Annexes II and IV to the EU Habitats Directive. It is also protected under the Wildlife Acts, 1976-2012 and is evaluated as being Near Threatened in the most recent Red Data list for mammals (Marnell et al., 2009). This species is distributed throughout Ireland and can have a home range of up to 10 or 20 km (NPWS, 2013). As per the NPWS Article 17 Reporting, the range, population, habitat and future prospects for this species in Ireland have been assessed as favourable.

The purpose of the otter survey was to identify any sensitive features within the study area potentially of use to breeding, resting, foraging or commuting otters and to establish presence or absence of otter activity.

The otter survey involved a search of the banks of the River Poddle and ponds for physical evidence of otters, e.g. spraints, prints, slides, trails, couches and holts. Particular attention was given to important riverine features within the survey corridor, such as under bridges. The survey methodology was also cognisant of the recommendations in the Otter Threat Response Plan 2009-2011 (NPWS, 2009) which recognises the importance of the riparian buffer (10 m on both banks) for otters and these areas were included in the survey corridor.

2.3.4 Wintering Bird Survey

The wintering bird survey was intended to determine which wintering bird species use the two parks and their numbers and distribution within the parks. The parks were divided into eight sectors. Each sector was further divided in sub-sectors depending on the characteristics of the habitats present. Each sub-sector represented a discrete area of similar habitat suitable for wintering birds, such as a pond or field. A map showing bird sectors is provided in Appendix B.

Bancroft Park and Tymon Park lie approximately 8.5 km from a number of Special Protection Areas (SPAs) in Dublin Bay. These SPAs are designated for wintering birds. As supplies of food found on the coast run out, many of these species, but in particular Light-bellied Brent Goose (*Branta bernicla hrota*), travel inland to feed. Playing fields and amenity grassland, such as those found in Bancroft Park and Tymon Park, provide valuable foraging habitat for these species.

Surveys were undertaken weekly and each survey lasted approximately 3.5 hours. Surveys involved walking a transect and scanning all areas of suitable habitat with ×10 binoculars. The direction as well as the start and end point was changed to vary the time that each area was visited. The species and number present in each subsector was recorded. Areas of open grassland were also searched for goose droppings.

The survey recorded all waterbirds, i.e. birds closely associated with aquatic habitat. This included all waterbird species as defined by Wetlands International (Wetlands International, 2006) and included all swans, geese, ducks, divers, grebes, Cormorant, Shag, herons, rails, crakes, waders and Kingfisher, as well as gulls. Incidental sightings of raptors and birds listed on Annex I to the Birds Directive were also recorded.

A description of each sector is provided below.

Tymon Park East

Sector A

This included the fields at the north end of Tymon Park east. It included the largest open field in the park and areas of grassland managed for biodiversity. The dog park is also within this sector. Construction of a pipeline through this area was continuous during the surveys.

Sector B

This sector included the three fields and the pond west of Tymon Lake. The fields were divided by hedgerows. The River Poddle followed one of the hedgerows to the pond.

Sector C

This sector included Tymon Lake and the grassland areas to the north and east along Limekiln Road. It also included the River Poddle to the point where it exits the park at Wellington Road.

Sector D

This sector consisted of five fields south of Tymon Lake between the M50 and Kennington Road.

Sector E

This sector included the fields between Templeogue United FC and the remainder of Tymon Park to the south. It also included the ponds at Faughs GAA Club.

Tymon Park West

Sector F

This sector included the fields around the National Basketball Arena and north as far as the visitor centre grounds.

Sector G

This sector included the remainder of Tymon Park West including the car park, the ponds and grassland areas around them, Coláiste de hÍde and the halting site. Significant construction works was ongoing next to Coláiste de hÍde during the surveys.

Bancroft Park

Bancroft Park was surveyed as one unit which included the amenity grassland and the River Poddle between Castletymon Road and Greenhills Road.

3. RESULTS

3.1 Desk Study

A review was undertaken of online sources of information in relation to Eurasian Badger, European Otter and wintering birds. The desk study identified one record of an otter in Tymon Park West (2016) and four records of badgers, two from Tymon Park West, one from Tymon Park East and one from Bancroft Park. Table 3.1 below lists the wintering birds recorded in the study area since 2007 (NBDC). Table 3.2 lists the consultees along with their responses.

Table 3.1. Wintering birds recorded in Tymon and Bancroft Parks (2007-2018).

Common Name	Scientific Name
Pochard	<i>Aythya ferina</i>
Teal	<i>Anas crecca</i>
Northern Shoveler	<i>Anas clypeata</i>
Little Egret	<i>Egretta garzetta</i>
Kingfisher	<i>Alcedo atthis</i>
Tufted Duck	<i>Aythya marila</i>
Brent Goose	<i>Branta bernicula</i>
Goldeneye	<i>Bucephala clangula</i>
Oystercatcher	<i>Haematopus ostralegus</i>
Golden Plover	<i>Pluvialis apricaria</i>
Great-crested Grebe	<i>Podiceps cristatus</i>
Water Rail	<i>Rallus aquaticus</i>
Little Grebe	<i>Tachybaptus ruficollis</i>
Greenshank	<i>Tringa nebularia</i>
Redshank	<i>Tringa totanus</i>
Northern Lapwing	<i>Vanellus vanellus</i>

Table 3.2. Consultation responses.

Consultee	Date of Response	Summary Response
National Parks & Wildlife Service	None received	n/a
South Dublin Branch of BirdWatch Ireland	None received	n/a
Irish Brent Goose Research Group	None received	n/a
Local Birdwatcher	7 th February	Geese have not used the park since c. 2012. A combination of disturbance by dogs and the construction of the dog park may have made the areas previously used unsuitable.
Park Ranger	23 rd January and 21 st February	Park rangers were consulted twice during the surveys. They said geese have not used the park in 2017/18. He said this might be due to ongoing construction work in the areas historically used.
Public	13 th February	Member of the public told surveyor that geese had not been to the park in a few years. He said he had seen Kingfisher recently on the west side of Tymon Park and on one occasion flying out of the culvert on the east side.

3.2 Field Surveys

3.2.1 Habitats

A list of the habitats identified in the study area during the field surveys is presented in Table 3.3 below, followed by a more detailed description below. Habitat mapping is provided in Appendix A.

Table 3.3. Habitats recorded in the study area. Habitat names and codes correspond to Fossitt (2000).

Habitat Name	Habitat Code	Total Area (m ²)	% of Total Area
Amenity Grassland	GA2	648,873	50.8
Dry Meadows and Grassy Verges	GS2	94,661	7.4
Buildings and Artificial Surfaces	BL3	102,636	8.0
Scrub	WS1	7,311	0.2
Mixed Broadleaf Woodland	WD1	246,152	19.3
Spoil and Bare Ground/ Mixed Broadleaf Woodland	ED2/WD1	8,199	0.6
Mixed Conifer/ Broadleaf Woodland	WD2	134,080	10.5
Immature Woodland	WS2	224	0.2
Artificial Lakes and Ponds	FL8	32,021	2.5
Reed and Large Sedge Swamps	FS1	1,616	0.1
Linear Habitats	Habitat Code	Length (m)	
Lowland/ depositing Rivers	FW2	3,263	
Drainage Ditches	FW4	1416	
Hedgerows	WL1	2,860	
Paths	BL3	12,966	

Amenity Grassland (GA2)

Amenity grasslands are heavily managed grassland that are usually species poor and mowed to maintain a short sward. Amenity grassland includes the pitches in Bancroft Park and Tymon Park and the areas of both parks that are regularly mown. This habitat is species-poor, being dominated by Perennial Rye-grass (*Lolium perene*) and clovers (*Trifolium* sp.). However, it can provide feeding habitat for wintering birds, especially Brent Geese.

Dry Meadows and Grassy Verges (GS2)

This habitat includes the areas of Tymon Park and Bancroft Park that are managed for biodiversity. These areas are mown once or twice a year and left standing over winter. These areas provide a food resource for birds and invertebrates. This habitat is also found along the River Poddle where it forms a buffer between amenity grassland and the river.

Buildings and Artificial Surfaces (BL3)

This habitat type includes car parks, roads, paths and buildings. Generally, built habitats are not considered of high ecological significance and do not offer high-quality floral or faunal habitat. In the study area these areas often had high densities of birds due to feeding by the public.

Scrub (WS1)

This habitat consists of areas of shrubs less than 5 m high. This habitat is found in Bancroft Park and in some areas of Tymon Park, often next to woodland. Common species include Gorse, Dogwood and Bramble. Scrub provides nesting habitat for birds and cover for mammals.

Mixed Broadleaf Woodland (WD1)

This habitat is the second most common habitat found in Bancroft and Tymon Parks, after amenity grassland. Most of this habitat was planted and is of a similar age. The most common tree species are beech, ash, oak, sycamore, alder, birch and hazel. The understory species visible during the survey were ivy and bramble. Development of the field layer is limited where the trees are densely planted and of similar age. Japanese Knotweed (*Fallopia japonica*) and Snowberry (*Symphoricarpos albus*) were recorded in this habitat.

Spoil and Bare Ground/Mixed Broadleaf Woodland (ED2/WD1)

This habitat mosaic is found behind the Tymon Park Visitor Centre. It includes areas where rubble, cuttings and chippings from park maintenance works are stored. The tree species composition is similar to that found in the broadleaf woodland elsewhere in the park.

Mixed Broadleaf/Conifer Woodland (WD2)

Some areas of Tymon Park have been planted with a mix of broadleaved and coniferous species. The species composition is similar to WD1 but includes Larch (*Larix deciduas*) and Scot's Pine (*Pinus sylvestris*). This habitat is found in parts of Tymon Park East.

Immature Woodland (WS2)

This habitat consists of recently planted mixed woodlands that have not reached 5 m in height. A small area of immature woodland was recorded in Tymon Park east.

Artificial Lakes and Ponds (FL8)

This habitat included the artificial or ornamental bodies of standing water that are found in Tymon Park. Although artificial in origin, the ponds are of particular biodiversity value as they support large number of waterbirds. The large number of waterbirds is attributed to feeding by people using the park. The natural habitats along the banks contain riparian species such as Common Reed (*Phragmites australis*), Bull Rush (*Typha latifolia*) and rushes (*Juncus* spp.). Small fish are present in the ponds and these were observed being preyed on by Little Grebe. Frog spawn was recorded in the shallow, still areas of the ponds. The invasive species Giant Rhubarb (*Gunnera tinctoria*) was recorded in two areas on the edges of the ponds in Tymon Park. This is an invasive species capable of displacing native flora.

Lowland/Depositing Rivers (FW2)

The River Poddle flows through Bancroft Park and Tymon Park. It is culverted under Castletymon Road and the M50. The channel has been straightened in several places and the banks have been reinforced. The flow is slow and the river is broken up by several ponds in Tymon Park. Lesser Water-parsnip was commonly found growing along the river edges. The River Poddle is frequently bordered by rough grassland, which protects the river from sedimentation and nutrient run-off and has added to the biodiversity value of the river. Litter is a significant problem, especially in Bancroft Park.

Drainage Ditches (FW4)

Drainage ditches commonly found associated with hedgerows and make up former field boundaries. Generally the ditches are ephemeral, only containing water after rainfall. They support wetland plants including rushes and provide breeding habitat for frogs.

Hedgerows (WL1)

These are managed strips of trees and shrubs which typically form field boundaries. Within the study area, hedgerows are found forming the old field boundaries in Tymon Park. Common species include Hawthorn, Ash, Ivy and Bramble.



Plate 1. The River Poddle in Tymon Park East.

3.2.2 Otter Survey

While no evidence of otters was recorded during the surveys, this species is likely to use the site. Otters have been recorded in Tymon Park as recently as 2016 (NBDC, 2018).

3.2.3 Badger Survey

Badgers are vulnerable to persecution. Therefore, the data pertaining to badgers in this report should be considered confidential and should not be made available to the public.

Two badger setts were recorded in Tymon Park West. The main sett (Sett 1) had 9 entrances in total, with 7 showing signs of recent use. Several of the holes had very large spoil heaps typical of this species. The sett is against the earth bank on the east side of Tymon Lane and may pre-date the foundation of the park.

A second sett (Sett 2) was recorded along the boundary of the park and the M50, close to the Visitor Centre. This sett had two entrances. Bedding was present in the spoil heaps. Both of the entrances were blocked with leaves suggesting the sett is not currently active. Snuffle holes were recorded 50 m north of the sett at the base of a tree.

Motion sensor cameras were placed at Sett 1 to record badger. In order to ascertain the movements of badger within the park, motion sensor cameras were also placed in the woodlands in Tymon Park East to establish if badger were present in this area. The locations of the badger setts are presented in Appendix A.

There were a number of limitations in carrying out the badger survey. Firstly, the level of disturbance in Tymon Park and Bancroft Park made detecting prints very difficult. The presence of dogs may have deterred badgers from marking territories with latrines, or dogs may have dug up the latrines. The placing of remote cameras had to be considerate of the potential for theft, and therefore the cameras were not always placed in optimum positions.

The presence of two badger setts – an active main sett and an inactive outlier sett – suggests that there is a single social group occupying the west side of Tymon Park. It is unlikely that badger would use the M50 overpasses or could access other relatively natural areas such as

the River Dodder corridor. The location of the setts and feeding signs show that badgers belonging to this social group use the entire area of Tymon Park West, and potentially Bancroft Park, which badgers may access though the culvert during low flow. The varied habitats including woodland, amenity grassland and hedgerows provide suitable foraging habitat. Leftover food from people feeding birds at the car park probably provides additional food. Leftover citrus fruit was noted regularly, a food that birds are unlikely to eat. The high level of disturbance of the site reduced the setting opportunities in the parks.

No badger setts or footage was recorded in Tymon Park East, although there is a mammal path leading from the Carr Golf Centre under the palisade fence and into the park which may be used by badger. It is possible that there is a sett in the grounds of the golf centre, which is relatively undisturbed.

Without capturing and marking badgers, there is no practical method for calculating badger populations (Tuytens et al., 2001). However, the badger population can be measured based on studies that involved capturing badgers in similar situations. In this situation, based on the habitats present and the levels of disturbance, the social group in Tymon Park is likely to consist of 3-5 individuals. Inbreeding in this isolated badger population poses a considerable risk to their long term survival.

Habitats for badgers could be enhanced by the thinning of woodlands which contain trees of uniform age and height, thereby allowing a more diverse field layer to develop as well as scrub which would provide cover for badgers to dig setts.



Plate 2. Entrance to Sett 1 showing recent signs of digging.



Plate 3. Badger Sett 2 entrance with bedding in spoil.



Plate 4. Still image showing a badger close to Sett 1.

3.2.4 Wintering Bird Survey

A summary of the results of the wintering bird survey is given in Table 3.4 below. A total of 19 species were recorded during the surveys. Five species, namely Brent Goose, Wigeon, Shoveler, Teal and Snipe are species that migrate to Ireland each winter.

The distribution of wintering birds in Tymon Park and Bancroft Park was consistent between January and mid-April 2018. The ponds contained the highest concentration of all species recorded other than gulls. This is because the ponds provide suitable habitat and they are

popular places for the public to feed birds. Gulls, ducks, Coot, Moorhen, Mute Swan, Grey Heron and Little Egret were all recorded at the ponds.

The car park off Castletymon Road supported high numbers of gulls as well as Mute Swans and Grey Heron. This is a popular place for the public to feed birds.

The areas of amenity grassland were often used by gulls. The field at the north end of Tymon Park East often had numbers exceeding 150 gulls.

Table 3.4. Wintering bird species recorded. (w) denotes a winter migrant. "Peak Count" is the highest number of a species recorded on a single date.

Common Name	Scientific Name	Peak Count
Mute Swan	<i>Cygnus olor</i>	17
Brent Goose (w)	<i>Branta bernicula</i>	10
Wigeon (w)	<i>Anas Penelope</i>	23
Teal (w)	<i>Anas crecca</i>	5
Mallard	<i>Anas platyrhynchos</i>	126
Tufted Duck	<i>Aythya marila</i>	15
Northern Shoveler (w)	<i>Anas clypeata</i>	9
Little Grebe	<i>Tachybaptus ruficollis</i>	9
Grey Heron	<i>Ardea cinerea</i>	8
Little Egret	<i>Egretta garzetta</i>	1
Coot	<i>Fulica atra</i>	60
Moorhen	<i>Gallinula chloropus</i>	39
Black-headed Gull	<i>Chroicocephalus ridibundus</i>	356
Common Gull	<i>Larus canus</i>	234
Feral goose	<i>Anser sp.</i>	3
Feral duck	<i>Anas sp.</i>	6
Herring Gull	<i>Larus argentatus</i>	79
Lesser Black-backed Gull	<i>Larus fuscus</i>	3
Snipe (w)	<i>Gallinago gallinago</i>	1

Wintering Species

Brent Goose

Light-bellied Brent Goose has a circumpolar distribution, breeding throughout the extreme high Arctic. The range extends from Greenland to Svalbard and northern Russia, continuing through Alaska to the Canadian Arctic Archipelago. The Canadian breeding population winters almost entirely in Ireland. The winter distribution in Ireland is wholly coastal, with large estuaries and areas of intertidal mudflats with fine sediments the preferred habitat.

Brent Goose, a particular focus of the surveys, was recorded flying over Tymon Park East on the 23rd January. The flock appeared to land in Greenhills Park to the east. Based on anecdotal evidence, Brent Geese have not used Tymon Park in recent years as a result of constant disturbance by dogs. In addition, a dog park was built next to the area that was used by Brent Geese in the fields at the north end of Tymon Park East. Construction activity was noted during the survey period. The areas traditionally used by Brent Geese are presented on the drawings in Appendix A.



Plate 5. Construction work in a field used historically by brent geese.

Wigeon

Wigeon is a medium-sized duck with a round head and small bill. The head and neck of the male are chestnut, with a yellow forehead, pink breast and grey body. In flight birds show white bellies and males have a large white wing patch. Wigeon were recorded regularly on Tymon Lake. The numbers recorded varied from 10 to 23 with numbers usually around 19 birds during the winter months.



Plate 6. Wigeon on Tymon Lake

Teal

Teal have a wide distribution across Eurasia and North America. In winter, the species occurs across much of Europe, wherever there are suitable wetland habitats, including both inland and coastal wetlands. Non-breeding teal are widespread throughout Ireland, favouring areas of shallow water on estuarine coastal lagoons, coastal and inland marshes, and flooded pastures and ponds. Teal were recorded consistently in small numbers (2-5) in Tymon Park East. They were recorded on the small pond above Tymon Lake, in Tymon Lake and along the River Poddle. They were easily flushed along the river channel.

Northern Shoveler

Shoveler is a medium- to large-sized duck with a long and broad bill. Males have a green head, white breast, chestnut belly and flanks and blue upper forewing. Females are similar to Mallard but distinguished by the bill and darker brown belly. The species is Red-listed in Ireland. Most occur between October and March. Shoveler was recorded on three occasions in February and March. One individual was recorded on the 5th February, nine were recorded on the 21st February and three were recorded on the 5th March.

Snipe

Snipe is a small wader with a long bill. It is well camouflaged and is usually only seen when flushed from long grass. When flushed, snipe typically fly in a frantic zig-zag fashion. Snipe occur in Ireland both as a winter migrant from the north and a summer visitor from North Africa and the Mediterranean. It is Amber-listed in Ireland due to a moderate decline. Snipe were recorded in March and April in the long grass managed for biodiversity in the northern end of Tymon Park East.

3.2.5 Invasive Species

Three invasive species listed on the Third Schedule to the European Communities (Birds and Natural Habitats) Regulations, 2011 (as amended) were identified during the walkover surveys. Two other species, namely Snowberry and Winter Heliotrope were recorded during the surveys. They form dense stands and pose a risk to biodiversity if allowed to spread.

Japanese Knotweed

Japanese Knotweed is a non-native, invasive, perennial plant with hollow, bamboo-like stems. Its leaves are approximately the size of a human hand and plants form yellow-cream flowers in late June to August. The plant consists of hollow bamboo-like stems which are green with red spots during summer and turn brown during winter. During growth red sideshoots form off the main stem and its leaves are arranged in a zig-zag pattern. Japanese Knotweed is on Invasive Species Ireland's list of the "most unwanted" species (Invasive Species Ireland is a joint project between the Northern Ireland Environment Agency and the National Parks & Wildlife Service). Japanese Knotweed is a threat in open and streamside areas. It can spread rapidly through underground stems (rhizomes) and fragmentation to form dense stands, excluding native vegetation and reducing species diversity. Japanese Knotweed does not produce viable seeds in Ireland. Rhizomes may spread up to 7 m horizontally and 3 m deep from the above-ground plant. Once stands become established, they are extremely persistent and difficult to remove. This plant has the ability to grow through tarmac and concrete (in some cases within dwellings). Failure to manage Japanese Knotweed on a development site may result in eventual structural damage.

Japanese Knotweed was identified on a woodland edge on the eastern side of Tymon Park close to the dog park (ITM 710407 729518). The stand was thinly spread throughout an area of approximately 8 m × 18 m.

Giant Rhubarb

Giant Rhubarb is a large herbaceous perennial, which can grow up to 2 m tall, with leaves of up to 2 m in diameter. It is a rhizomatous plant and the rhizomes of mature plants can be up to 1.5-2 m long growing above ground. It is deciduous with the leaves dying off in autumn (October), leaving the large brown rhizomes exposed. Growth starts in early spring (March), prior to the emergence of native species. It can reproduce by both sexual (seed) and asexual

(vegetative) means. Inflorescence development occurs early in the spring, with the fruits maturing in late summer/early autumn. Large numbers (up to 250,000 seeds per mature plant) of drupe like, red or orange seeds are produced. Small fragments of the rhizome have the potential to establish new plants. The impacts of concern are colonisation of peat bog and waterside vegetation where large dense colonies can rapidly dominate and displace important native species. Colonisation of agricultural and amenity areas can lead to these areas being unusable due to the dense stands of Giant Rhubarb.

Giant Rhubarb was identified on the western shore of Tymon Lake and also along the stream flowing into Tymon Lake from the west (ITM 710708 729367).

Grey Squirrel

Grey Squirrel, a non-native species which was introduced to Ireland in 1911 is an invasive forest mammal. It has had a negative impact on the native Red Squirrel through competition and possibly disease, and has caused considerable damage to Irish woodland through its habitat of bark stripping trees. Grey Squirrel has spread from its original point of introduction to cover much of the eastern half of the island of Ireland. Grey Squirrel has not, however, established itself in the west of Ireland, with the River Shannon marking the western boundary of its range. In its range, Grey Squirrels readily associate with human environments such as public parks and suburban gardens. During the surveys, Grey Squirrels were regularly recorded in Tymon Park West.

3.2.6 Other Species

Other species of interest recorded during the survey include a number of raptors, namely Common Buzzard, Peregrine and Sparrowhawk. Buzzards and sparrowhawks were recorded within the parks themselves, while a peregrine was seen above Bancroft Park. It is likely that buzzard are attracted by the high numbers of rabbits that occur in Tymon Park. Similarly, sparrowhawks are likely to feed on the high numbers of birds such as finches, blackbirds and thrushes, all of which are numerous in the parks.

Grey Wagtail and Redwing were both recorded occasionally in Bancroft Park and Tymon Park. Grey Wagtail is a wetland insectivore that was recorded along the Poddle in Bancroft Park. Redwings were occasional recorded in Tymon Park. This thrush species is a winter visitor from Eastern Europe.

4. DISCUSSION

The potential impacts resulting from the construction of the flood embankments include:

- Disturbance during construction;
- Reduced habitat quality as a result of the embankments and flood walls; and,
- Impacts from the increase in areas flooded.

The following sections describe the potential impacts of the construction of the flood alleviation measures and associated flood events on badgers, otters, wintering birds and invasive species.

4.1 Badger

Two badger setts were identified in Tymon Park West. The locations of the two setts are away from the flood alleviation works and the area that will be flooded. Therefore, badger setts will not be impacted by the works. The construction of the works may result in temporary noise and light disturbance. However, it is anticipated that these impacts can be reduced through appropriate work practices.

4.2 Otter

No otters or otter signs were recorded during the field surveys. However, there are records of otters in Tymon Park from 2016. The construction of the works may result in temporary noise and light disturbance, but these impacts can be reduced through appropriate work practices.

4.3 Wintering Birds

Tymon Park and Bancroft Park support five species of wintering birds and at least 13 other species of wetland birds, including gulls. Wintering and wetland birds were concentrated in the ponds in Tymon Park.

Wintering birds may be impacted through increased noise, vibration and people present in the park. If works were to be carried out during winter, it is likely that species such as Wigeon, Teal and Shoveler would be displaced.

The construction of embankments around the ponds will reduce the sightlines from the water to safe areas currently utilised by birds. This could reduce the suitability of the ponds for wintering birds, causing them to flush more easily and reducing the efficiency with which they can feed. However, it should be noted that Tymon Lake and the other ponds are already subject to disturbance and are enclosed by reed beds, trees and hedgerows. Therefore, the embankments are unlikely to deter the species currently present from using the ponds.

Brent geese were not recorded in Bancroft Park or Tymon Park during the surveys. This may be due to the increased pressures from people, dogs and construction activities. Brent geese are known to have historically used the fields at the northern end of Tymon Park East (see Appendix A). This area provides a suitable sward height and adequate sightlines for this species. These fields are not in the vicinity of the proposed works and, therefore, brent geese behaviour is unlikely to be impacted by the proposed flood alleviation works.

4.4 Invasive Species

The surveys recorded two listed invasive species in Tymon Park, namely Japanese Knotweed and Giant Rhubarb. Of these, only Giant Rhubarb was recorded in the vicinity of the works. This species was recorded on the western shore of Tymon Lake and also along the stream flowing into Tymon Lake from the west. This species spreads by producing huge amounts of seed and the seed is likely to be present in the soil on the banks of Tymon Lake. Measures should be taken to prevent the accidental spread of this species within and outside Tymon Park. This should take the form of an Invasive Species Management Plan which should be included in the Construction Management Plan.

5. RECOMMENDATIONS

5.1 Badgers

This report contains information on the locations of badger setts and should be considered confidential. Although there are no badger setts in the vicinity of the proposed works, badger activity may still be impacted by construction activities. To reduce the impacts on badger, the following measures should be included the Construction Management Plan:

- Works should be programmed to occur during the hours of daylight only.
- Any excavations greater than 1 m deep should be securely covered at night or a ramp provided to enable animals to escape should they fall in.
- Flood-lighting of the works areas should be avoided.

5.2 Otter

No otters were recorded during the surveys. However, they have been recorded in Tymon Park as recently as 2016. To reduce the impacts on otter, the following measures should be included the Construction Management Plan:

- Works should be programmed to occur during the hours of daylight only.
- Any temporarily exposed open pipe system should be capped in such a way as to prevent otters gaining access, as may happen when contractors are off-site.
- Flood-lighting of the works areas should be avoided.

5.3 Invasive Species

The Parks Department of South Dublin County Council should be notified about the presence of Japanese Knotweed and Giant Rhubarb within Tymon Park East and arrangements should be made to treat these species with herbicide suitable for use near watercourses and in the appropriate season.

5.4 Wintering Birds

In order to reduce the impacts on wintering birds, the following measures should be included in the Construction Management Plan:

- There should be no planting on the flood embankments.
- Works should begin in late April to avoid impacts on wintering birds.

5.5 Water Quality

Best practice procedures from Inland Fisheries Ireland (IFI, 2016) should be incorporated into the design of the Project. The following is an overview of general design measures that should be employed during the construction of the Project to minimise and avoid negative impacts within the footprint and on the wider environment.

Earthworks

- The Construction Method Statement should be read and approved by the Site Foreman and the Works Team inducted by the Site Foreman on the ecological considerations detailed in the Construction Method Statement.
- Felling and hedge cutting within the bird breeding season (1st March to 31st August) should be avoided. If vegetation removal is required within the bird breeding season, trees should be examined for birds by a suitable qualified ecologist prior to felling.
- Prior to any excavation works, the works area should be assessed and clearly delineated with temporary fencing. There should be no access by works vehicles outside the fenced-off areas.

- All storage of plant, excavated material and topsoil and other materials required for construction and landscaping should be held within the fenced area.
- No washing of plant, vehicles or equipment should be completed within 50 m of a watercourse. The Site Foreman should ensure that all deliveries are required to complete wash-out at their own company base, not on-site.

Hydrocarbon usage

The use of hydrocarbons during the construction process leads to the potential for pollution to enter the wider environment, including drainage ditches and watercourses. Leaks in poorly maintained plant and machinery could lead to hydrocarbon dispersal over works areas. Leaks in fuel storage tanks and spillages during refueling operations could lead to larger releases of hydrocarbons into the environment.

The use of machinery carries the potential for accidental hydrocarbon contamination of works areas, by fuel spillages or oil leaks for example. The works should be carried out in accordance with the following measures to avoid such impacts:

- All machinery should be refuelled from mobile tankers on the local or access roads. No refuelling should take place within 50 m of any watercourse.
- Mobile storage such as fuel bowsers should be bunded to 110% capacity to prevent spills. Tanks for bowsers and generators should be double-skinned.
- When not in use, all valves and fuel trigger guns from fuel storage containers should be locked.
- All plant refuelling should take place using mobile fuel bowsers. Only dedicated trained and competent personnel should carry out refuelling operations. Plant refuelling should take place as far as practicable from watercourses. A spill kit and drip tray should be on site at all times and available for all refuelling operations. Equipment should not be left unattended during refuelling. All pipework from containers to pump nozzles should have anti-siphon valves fitted.
- Strict procedures for plant inspection, maintenance and repairs should be detailed in the Contractor's method statements and machinery should be checked for leaks before arrival on site.
- All site plant should be inspected at the beginning of each day prior to use. Defective plant should not be used until the defect is satisfactorily fixed.
- All major repair and maintenance operations should take place off-site.
- Care should be taken at all times to avoid contamination of the environment with contaminants other than hydrocarbons, such as uncured concrete or other chemicals.
- Specific measures to off-set potential impacts relating to surface water run-off, during the operation of the road, have been incorporated into the design of the Project. These include the use of hydrocarbon interceptors and attenuation systems.

Protection of watercourses

- No direct discharges should be made to waters where there is cement or residues in discharges.
- There should be no visible oil film on any discharges from construction works to waters.
- Silt fences should be used, as required, to prevent sediment from contaminating the watercourses.

6. ECOLOGICAL ENHANCEMENTS

Ireland's national biodiversity action plan Actions for Biodiversity 2017-2021 (DAHG, 2011), in accordance with the Convention on Biological Diversity, is a framework for the conservation and protection of Ireland's biodiversity, with an overall objective to secure the conservation, including, where possible, the enhancement and sustainable use of biological diversity in Ireland and to contribute to collective efforts for conservation of biodiversity globally. Action 1.1.3 of the National Biodiversity Strategy aspires that "all Public Authorities and private sector bodies move towards no net loss of biodiversity through strategies, planning, mitigation measures, appropriate offsetting and/or investment in Blue-Green infrastructure". This is particularly relevant to developments.

6.1 Woodland thinning

In many areas of the parks, planted woodland has a uniform canopy height resulting in a homogenous understory. The trees, competing for light, have grown tall and thin and, in time, will be subject to wind throw. In addition, the competition for light weakens the trees making them more susceptible to insects and disease.

By thinning out the weakest trees and reducing the competition for light, the remaining trees will be able to develop more resistance to environmental stresses. In addition, by opening the canopy, more light will reach the woodland floor and promote the development of a more diverse understory and field layer. This will provide more habitat for invertebrates, mammals and birds. Having trees of varying ages in the woodland will also improve the visual appearance of the wood and create an "old growth" forest character. Thinning of trees should include felling weaker trees and leaving them in-situ as invertebrate habitat. Other trees can be cut all the way around the trunk and left as standing dead trees.

The protection of bird breeding habitats during the breeding season (1st March to 31st August, inclusive), is set out in the Wildlife Acts, 1976-2012. Any removal of vegetation within this period should be avoided.

6.2 Rejuvenation of the River Poddle

The River Poddle has the potential to be enhanced through the rehabilitation of existing habitats and creation of new ones. It is important for ecologically healthy watercourses to have habitat heterogeneity, which is achieved by a variety of pools, waterfalls and riffles being present, in addition to varying amounts of flow and shading by vegetation. Litter should be removed from the river and dead wood should be left in-situ.

6.3 Bat Boxes and Bird Boxes

The lack of dense scrub and old trees with holes and cracks suitable for nesting and roosting means that the provision of artificial boxes for birds and bats could enhance the capacity of the parks for birds and bats. Boxes should be placed in suitable locations and at least 3 m high, to prevent vandalism. Bat boxes should be positioned following guidance in Stebbings (1991). Boxes should be placed out of view of paths to avoid disturbance. Bird boxes of different types should be used in order to cater for a variety of species. Bat boxes should be of the self-cleaning type.

6.4 Removal of Non-native Plants

Three non-native shrubs were identified during the surveys and without treatment these will displace native flora. In particular, Japanese Knotweed and Giant Rhubarb should be treated as a matter of urgency. Herbicide should be suitable for use near watercourses and be used sparingly and damage to the native flora avoided where possible.

7. CONCLUSION

- Wintering birds use Tymon Park and may be impacted by the proposed flood alleviation works.
- Badgers are present in Tymon Park. However, there are no setts near the proposed works.
- Brent geese were recorded flying low over Tymon Park on one occasion during the surveys. No Brent geese or evidence of this species was recorded within the parks during the surveys between January and April 2018.
- Four species of wintering birds: Teal, Northern Shoveler, Wigeon and Snipe were recorded during the survey.
- The recommendations outlined in Section 5 should be adhered to.

In conclusion, given the full implementation of the recommendations in Section 5 of this report, the proposed flood alleviation measures as described in the Eastern CFRAM Study Puddle Options Report (RPS, 2014) will not result in any impacts on wintering birds, badgers or otters.

8. REFERENCES

- CIEEM (2016) *Guidelines for Ecological Impact Assessment in the UK and Ireland. Terrestrial, Freshwater and Coastal. 2nd ed.* Chartered Institute of Ecology and Environmental Management, Winchester.
- European Communities (Birds and Natural Habitats) Regulations, 2011. *SI No. 477/2011.*
- European Communities (Birds and Natural Habitats) (Amendment) Regulations, 2013. *SI No. 499/2013.*
- European Communities (Birds and Natural Habitats) (Amendment) Regulations, 2015. *SI No. 355/2015.*
- Fossitt, J.A. (2000) *A Guide to Habitats in Ireland.* The Heritage Council, Kilkenny.
- IFI (2016) Guidelines on Protection of Fisheries during Construction Works in and Adjacent to Waters. Inland Fisheries Ireland, Dublin.
- Kingston, N. (2012) *Checklist of protected and rare species in Ireland. Unpublished Report.* National Parks & Wildlife Service, Dublin.
- Marnell, F., Kingston, N. & Looney, D. (2009) Ireland Red List No. 3: Terrestrial Mammals, National Parks and Wildlife Service, Department of the Environment, Heritage and Local Government, Dublin, Ireland
- NBDC (2018) *Biodiversity Maps* <<http://maps.biodiversityireland.ie/#/Map>> [Accessed 17/01/2018]. National Biodiversity Data Centre, Waterford.
- NPWS (2009) *Threat Response Plan: Otter (2009-2011).* National Parks & Wildlife Service, Department of the Environment, Heritage and Local Government, Dublin.
- NPWS (2013) *The Status of EU Protected Habitats and Species in Ireland. Volume 2 (Habitat Assessments) and Volume 3 (Species Assessments).* National Parks & Wildlife Service, Department of Arts, Heritage and the Gaeltacht, Dublin.
- NPWS (2018) *Online Map Viewer* <<http://webgis.npws.ie/npwsviewer/>> [Accessed 17/01/2018]. Department of Arts, Heritage and Gaeltacht, Dublin.
- NRA (2006a) *Guidelines on the Treatment of Badger Prior to the Construction of National Road Schemes.* National Roads Authority, Dublin.
- NRA (2008b) *Guidelines on the Treatment of Otter Prior to the Construction of National Road Schemes.* National Roads Authority, Dublin.
- NRA (2008c) *Guidelines on Ecological Surveying Techniques for Protected Flora and Fauna on National Road Schemes.* National Roads Authority, Dublin.
- NRA (2009a) *Environmental Impact Assessment of National Road Schemes – A Practical Guide.* National Roads Authority, Dublin.
- NRA (2009b) *Guidelines for Assessment of Ecological Impacts of National Road Schemes.* National Roads Authority, Dublin.
- RPS (2014) Eastern CFRAM Study Puddle Options Report. Office of Public Works. http://eastcfram.irish-surge-forecast.ie/wp-content/uploads/2011/10/IBE0600Rp0030_Puddle-Options-Report_F02.pdf
- Smith, G.F., O'Donoghue, P., O'Hora, K. and Delaney, E. (2011) *Best Practice Guidance for Habitat Survey and Mapping.* The Heritage Council, Kilkenny.

Stebbing, R.E. (1991) *Natterer's Bat*. In: Corbet, G.B. and Harris, S. (eds.) *The Handbook of British Mammals*, pp.102-105. Blackwell, Oxford.

Tuytens, F.A.M., Long, B., Fawcett, T., Skinner, A., Brown, J.A., Cheeseman, C.L., Roddam, A.W. and Macdonald, D.W. (2001) *Estimating group size and population density of Eurasian badgers *Meles meles* by quantifying latrine use*. *Journal of Applied Ecology*, 38: 1114-1121.

Wildlife Act, 1976. *No. 39 of 1976*.

Wildlife Act, 1976 (Protection of Wild Animals) Regulations, 1990. *SI No. 112/1990*.

Wildlife (Amendment) Act, 2000. *No. 38 of 2000*.

Wildlife (Amendment) Act, 2012. *No 29 of 2012*.

APPENDIX A

Mapping



Legend

FW2-Depositing/Lowland Rivers	WD1 - (Mixed) Broadleaved Woodland
BL3 - Building and Artificial Surface	WD2 - Mixed Broadleaved / Conifer Woodland
GA2 - Amenity Grassland (Improved)	WS1 - Scrub
GS1 - Dry Calcareous and Neutral Grassland	

Source: Esri, DigitalGlobe, GeoEye, Earthstar Geographics, CNES/Airbus DS, USDA, USGS, AEX, Getmapping, Aerogrid, IGN, IGP, swisstopo, and the GIS User Community

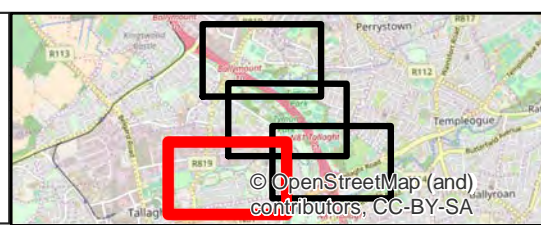

PROD
ROUGHAN & O'DONOVAN
Consulting Engineers
Civil - Structural - Transportation - Environmental

Drawn LA	Designed KM	Checked POS	Approved BC	Suitability Code - Description S2 - Information / Planning
-------------	----------------	----------------	----------------	---

Project Stage		TYMON PARK WINTER HABITAT STUDY				
Drawing Title		HABITAT MAPPING SHEET 1 OF 4				
Project	Originator	Volume	Location	Type	Role	Number
TPW	ROD	EBD	SW_AE	DR	EN	00001
Scale (A1)	1:4,000	Date:	June 2018	Job No:	18.104	Rev:



Legend

- B Badger Sett
- FW2-Depositing/Lowland Rivers
- FW4-Drainage Ditches
- WL1-Hedgerows
- BL3 - Building and Artificial Surface
- FL8 - Other Artificial Lakes and Ponds
- FS1 - Reed and Large Sedge Swamp
- GA2 - Amenity Grassland (Improved)
- GS2 - Dry Meadows and Grassy Verges
- WD1 - (Mixed) Broadleaved Woodland
- WD2 - Mixed Broadleaved / Conifer Woodland

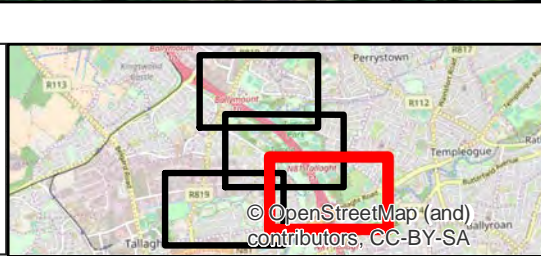

PROD
ROUGHAN & O'DONOVAN
Consulting Engineers
Civil - Structural - Transportation - Environmental

Arena House, Arena Road,
Sandyford,
Dublin 18, Ireland
t +353 (0) 1 294 0800
f +353 (0) 1 294 0820
www.rod.ie

Drawn LA	Designed KM	Checked POS	Approved BC	Suitability Code - Description S2 - Information / Planning
-------------	----------------	----------------	----------------	---

Project Title		TYMON PARK WINTER HABITAT STUDY				
Drawing Title		HABITAT MAPPING SHEET 2 OF 4				
Project	Originator	Volume	Location	Type	Role	Number
TPW	ROD	EBD	SW_AE	DR	EN	00002
Scale (A1)	1:4,000	Date:	June 2018	Job No:	18.104	Rev:



Legend

- B Badger Sett
- G Historical Brent Goose Feeding Areas
- FW2-Depositing/Lowland Rivers
- FW4-Drainage Ditches
- WL1-Hedgerows
- WL2-Treeline
- BL3 - Building and Artificial Surface
- ED2 / WD1, Spoil and Bare Ground / (Mixed) Broadleaved Woodland
- FL8 - Other Artificial Lakes and Ponds
- FS1 - Reed and Large Sedge Swamp
- GA2 - Amenity Grassland (Improved)
- GS1 - Dry Calcareous and Neutral Grassland
- GS2 - Dry Meadows and Grassy Verges
- WD1 - (Mixed) Broadleaved Woodland
- WD2 - Mixed Broadleaved / Conifer Woodland
- WS1 - Scrub
- WS2 - Immature Woodland

Source: Esri, DigitalGlobe, GeoEye, Earthstar Geographics, CNES/Airbus DS, USDA, USGS, AEX, Geomatics, AeroGRID, IGN, IGP, swisstopo, and the GIS User Community

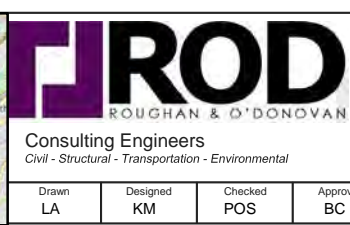
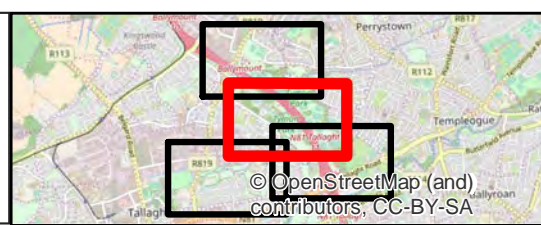

Arena House, Arena Road, Sandyford, Dublin 18, Ireland t +353 (0) 1 294 0800 f +353 (0) 1 294 0820 www.rod.ie		Project Title: TYMON PARK WINTER HABITAT STUDY	
Drawing Title: HABITAT MAPPING SHEET 3 OF 4		Project Originator Volume Location Type Role Number	
Drawn: LA	Designed: KM	Checked: POS	Approved: BC
Suitability Code - Description: S2 - Information / Planning		Project: TPW	Originator: ROD
Scale (A1): 1:4,000		Volume: EBD	Location: SW_AE
Date: June 2018		Type: DR	Role: EN
Job No: 18.104		Number: 00003	Rev:



- Legend**
- G Historical Brent Goose Feeding Areas
 - FW2-Depositing/Lowland Rivers
 - FW4-Drainage Ditches
 - WL1-Hedgerows
 - BL3 - Building and Artificial Surface
 - FL8 - Other Artificial Lakes and Ponds
 - FS1 - Reed and Large Sedge Swamp
 - GA2 - Amenity Grassland (Improved)
 - GS2 - Dry Meadows and Grassy Verges
 - WD1 - (Mixed) Broadleaved Woodland
 - WD2 - Mixed Broadleaved / Conifer Woodland
 - WS1 - Scrub
 - WS2 - Immature Woodland

Source: Esri, DigitalGlobe, GeoEye, Earthstar Geographics, CNES/Airbus DS, USDA, USGS, AEX, Getmapping, Aerogrid, IGN, IGP, swisstopo, and the GIS User Community

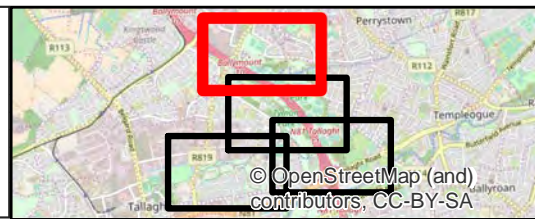

PROD
ROUGHAN & O'DONOVAN
Consulting Engineers
Civil - Structural - Transportation - Environmental

Drawn LA	Designed KM	Checked POS	Approved BC	Suitability Code - Description S2 - Information / Planning
-------------	----------------	----------------	----------------	---

Project Title		TYMON PARK WINTER HABITAT STUDY				
Drawing Title		HABITAT MAPPING SHEET 4 OF 4				
Project	Originator	Volume	Location	Type	Role	Number
TPW	ROD	EBD	SW_AE	DR	EN	00004
Scale (A1)	1:4,000	Date:	June 2018	Job No:	18.104	Rev:

Appendix B Bird Sectors



Source: Esri, DigitalGlobe, GeoEye, Earthstar Geographics, CNES/Airbus DS, USDA, USGS, AEX, Getmapping, Aerogrid, IGN, IGP, swisstopo, and the GIS User Community

Legend

- Sector F
- Sector G
- Bancroft Park

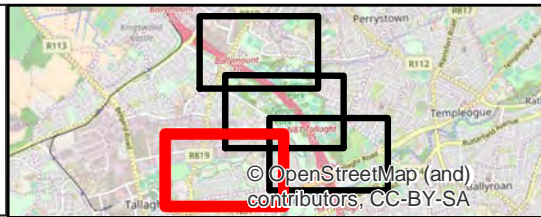

PROD
ROUGHAN & O'DONOVAN
Consulting Engineers
Civil - Structural - Transportation - Environmental

Drawn LA	Designed KM	Checked POS	Approved BC	Suitability Code - Description S2 - Information / Planning
-------------	----------------	----------------	----------------	---

Arena House, Arena Road,
Sandyford,
Dublin 18, Ireland
t +353 (0) 1 294 0800
f +353 (0) 1 294 0820
www.rod.ie

Project Stage	TYMON PARK WINTER HABITAT STUDY						
Drawing Title	BIRD SECTORS SHEET 1 OF 4						
Drawing Number	Project TPW	Originator ROD	Volume EBD	Location SW_AE	Type DR	Role EN	Number 00101
Scale (A1)	1:4,000	Date	June 2018	Job No	18.104	Rev.	



Legend

- Sector C
- Sector E
- Sector F
- Sector G

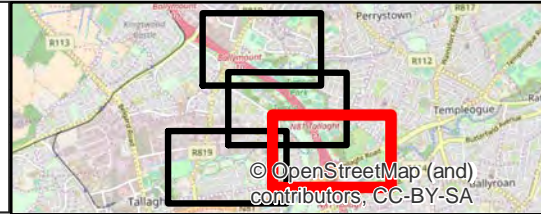

PROD
ROUGHAN & O'DONOVAN
Consulting Engineers
Civil - Structural - Transportation - Environmental

Drawn LA	Designed KM	Checked POS	Approved BC	Suitability Code - Description S2 - Information / Planning
-------------	----------------	----------------	----------------	---

Arena House, Arena Road,
Sandyford,
Dublin 18, Ireland
t +353 (0) 1 294 0800
f +353 (0) 1 294 0820
www.rod.ie

Project Title		TYMON PARK WINTER HABITAT STUDY					
Drawing Title		BIRD SECTORS SHEET 2 OF 4					
Project	Originator	Volume	Location	Type	Role	Number	
TPW	ROD	EBD	SW_AE	DR	EN	00102	
Scale (A1)	1:4,000	Date:	June 2018	Job No:	18.104	Rev:	



Legend

- Sector B
- Sector C
- Sector D
- Sector E
- Sector F
- Sector G
- Bancroft Park

Source: Esri, DigitalGlobe, GeoEye, Earthstar Geographics, CNES/Airbus DS, USDA, USGS, AEX, GeoMapping, AeroGRID, IGN, GP, swisstopo, and the GIS User Community

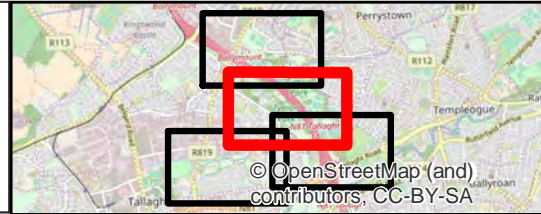

ROD
ROUGHAN & O'DONOVAN
Consulting Engineers
Civil - Structural - Transportation - Environmental

Drawn LA	Designed KM	Checked POS	Approved BC	Suitability Code - Description S2 - Information / Planning
-------------	----------------	----------------	----------------	---

Arena House, Arena Road,
Sandyford,
Dublin 18, Ireland
t +353 (0) 1 294 0800
f +353 (0) 1 294 0820
www.rod.ie

Project Title	TYMON PARK WINTER HABITAT STUDY						
Drawing Title	BIRD SECTORS SHEET 3 OF 4						
Drawing Number	Project	Originator	Volume	Location	Type	Role	Number
TPW	ROD	EBD	SW_AE	DR	EN		00103
Scale (A1)	1:4,000	Date:	June 2018	Job No:	18.104	Rev:	



Legend

- Sector A
- Sector B
- Sector C
- Sector D
- Sector G

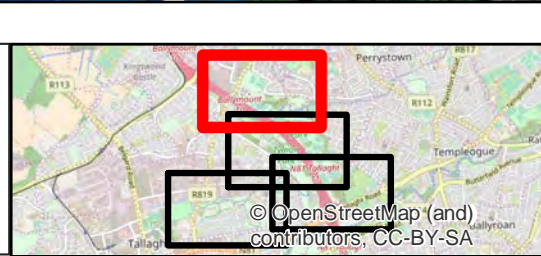

ROD
ROUGHAN & O'DONOVAN
Consulting Engineers
Civil - Structural - Transportation - Environmental

Arena House, Arena Road,
Sandyford,
Dublin 18, Ireland
t +353 (0) 1 294 0800
f +353 (0) 1 294 0820
www.rod.ie

Drawn LA	Designed KM	Checked POS	Approved BC	Suitability Code - Description S2 - Information / Planning
-------------	----------------	----------------	----------------	---

Project Title	TYMON PARK WINTER HABITAT STUDY						
Drawing Title	BIRD SECTORS SHEET 4 OF 4						
Drawing Number	Project TPW	Originator ROD	Volume EBD	Location SW_AE	Type DR	Role EN	Number 00104
Scale (A1)	1:4,000	Date	June 2018	Job No	18.104	Rev.	

Appendix C Bird Counts

British Trust for Ornithology (BTO) Species Codes

BG	Brent Goose
BH	Black-headed Gull
CM	Common Gull
CO	Coot
ET	Little Egret
H.	Grey Heron
HG	Herring Gull
LB	Lesser Black-backed Gull
LG	Little Grebe
MA	Mallard
MH	Moorhen
MS	Mute Swan
SN	Snipe
SV	Northern Shoveler
T.	Teal
TU	Tufted Duck
WN	Wigeon
ZF	Feral Duck
ZG	Feral Goose

SECTOR A

Table1. All counts for Sector A

Date	BG	BH	CM	HG	SN
5th January			102	2	
15th January		42	115		
23rd January	10	50	90		
5th February		19	100		
14th February		16	77	6	
21st February		7	70		
8th March		18	22		1
13th March		10	41		
20th March		30	23		
5th April			1		1
12th April			5		

SECTOR B

Table 2. All counts for Sector B

Date	BH	CM	CO	HG	LG	MA	MH	MS	TU	ZF
5 th January	16			2		8	2			
15 th January	35					7	1	2		
23 rd January	26	1				14	2			1
29 th January	11	3				13	1	3		1
5 th February	3		1			9	2			1
14 th February						8		2		1
21 st February			1		1	2				
8 th March	1		3			3	1			
13 th March	6		2			5	2		2	1
20 th March			4			5	2	4	9	2
27 th March			1		1	5	1	4		
5 th April			1			2	1		4	
12 th April			2	2		4	2	2	1	

SECTOR C

Table 3. All counts for Sector C

Dates	BH	CM	CO	HG	LB	LG	MA	MH	MS	SV	T.	TU	WN	ZL
5th January	93	2	58	5		1		26	6		2	2	10	1
15th January			36			6	5	5	8		5		23	1
23rd January	85	3	28	10		3	23	13	6		3		23	1
29th January	21		37			2	15	19	6		2	4	20	1
5th February	27		21			3	26	16	6	1	5	1	18	1
14th February	68	5	19	7		3	21	16	6		3	3	21	1
21st February	47		13	1		6	21	19	6	9			18	1
8th March	90	20	16	2		1	15	15	6	3	4	3	10	1
13th March	45		19			7	18	16	6		3	7		1
20th March	102	23	14	15	2	4	18	9	2			5		1
27th March	14		11	9		2	20	5	4		2			1
5th April	1		6	18	3		13	11	6		2	2		1
12th April			8	13	2	1	17	4	4			2		

SECTOR D

Table 4. All counts for Sector D

Date	BH	CM	HG
15th January	73	11	
23rd January	2		
5th February	1	1	
14th February	89	142	25
8th March	25	20	1

SECTOR E

Table 5. All counts for Sector E

Date	BH	CM	CO	ET	H.	HG	LG	MA	MH	MS	TU	ZF
5th January	67	2	2		4	5		43	11	4	6	
15th January			2		1	4	1	33	10	5	8	
23rd January	109		4		1		1	31	9	5	10	
29th January	17		3	1			1	22	10	5	11	
5th February	53	2	5		1	4	1	21	4	5	13	
14th February	66	6	3		2	39		19	7	5	10	
21st February	42		4					24	6	5	18	1
8th March	51	5	4			1	1	19	11	5	6	
13th March	52		4					32	4	5	9	1
20th March	29	2	2				2	19	6	5	2	
27th March			4				2	19	7	5	28	
5th April			1				2	20	6	3	20	
12th April			3		1		2	17	6	3	16	2

SECTOR F

Table 6. All counts for Sector F

Date	BH	CM	HG
5th January	7	2	
15th January	4	2	
23rd January	2		
29th January	3		
5th February	15	4	
14th February	9	4	
8th March	15	6	2
13th March	1	1	
12th April	7	3	

SECTOR G

Table 7. All counts for the Sector G

Date	BH	CM	CO	H.	HG	LB	LG	MA	MH	MS	T.	TU	ZF	ZL
5th January	124	1		5	2			42		2	3		3	2
15th January	2			5			2	68	4	2				2
23rd January	65		1	5			3	60	12	2			5	2
29th January			2	1			1	58	5	1			3	2
5th February	1		1	2				34	4	2			2	2
14th February	98		3	6	2			65	7	2			2	2
21st February			3	8			2	28	4	2			4	2
8th March	66		2	6		1		22	2	2			2	2
13th March	112	1	3	3				40	5	2			2	2
20th March	52		4	8			2	17	2	2			2	2
27th March			4	5			2	29	4	2			4	2
5th April			2	7		1		23	2	2			2	2
12th April			1					31	2	2		1	2	2

BANCROFT PARK

Table 8. All counts for Bancroft Park

Date	BH	ET	H.	LB	MA
5th January	21		1		
23rd January	2				
29th January	3				
5th February	15				
14th February		1			
5th April					2
12th April				1	



ROUGHAN & O'DONOVAN CONSULTING ENGINEERS

Arena House

Arena Road

Sandyford

Dublin 18

D18 V8P6

Ireland

Phone +353 1 294 0800

Email info@rod.ie

APPENDIX 7-2. Poddle River – Ecological Reports Relating to the Poddle River Flood Alleviation Measures, Mammal, Bird and Botanical Reports, Brian Keeley and Malgorzata Goska Wilkowska, 03-10-2018

Poddle River – Ecological Reports relating to the Poddle River Flood Alleviation Measures

Mammal, Bird and Botanical reports

Brian Keeley and Malgorzata Goska Wilkowska

03-10-2018

Introduction

These ecological evaluations were undertaken at the request of Gerard O'Connell, Dublin City Council, Engineer-in-Charge, . The aim of the assessment is a flora and fauna survey highlighting flora or fauna of scientific interest at this location. The proposed development site is situated along River Poddle, Dublin and includes Mount Argus Park. The site is linear and is 1.6 km long.

The surveys dealt with the flora and fauna that may be altered during the construction or operation of flood prevention measures along the Poddle River and included the following:

Flora – flowering plants, shrubs and trees Fauna – Ground mammals, bats, birds

The site is not suitable or recorded as a location for protected aquatic invertebrates including the freshwater pearl mussel or the freshwater crayfish and no further examinations for these species were undertaken.

Surveying was principally dealt with by two ecologists; Flora –	Malgorzata Wilkowska
Fauna	Brian Keeley

Surveying was all undertaken in the period August to September of 2018 at a time when flowering plants are very much in evidence and when birds were numerous but had mostly finished nesting (with several species continuing for a number of weeks more), bats are in the mating phase of the annual cycle and ground mammals such as badgers are highly active searching for wetter soil where invertebrates are more easily found and dug up.

The methodology for all surveys is given below:

Methodology

Flora

The habitat and botanical survey of the proposed development site took place on 01/08/2018 which is an optimal date for undertaking such surveys. Habitats were assessed and evaluated according to their occurrence as protected habitats under Annex I of the EU Habitats Directive (92/43/EEC) and for their capacity to support rare, threatened and endangered species.

Botanical species were assessed in accordance with their occurrence on the Flora Protection Order (1999) and The Irish Red Data Book (Curtis & McGough, 1988).

Fauna

Birds

The site along the Poddle River, Kimmage, Dublin was visited on 2018 to examine the site for evidence of occupancy or usage by protected birds. All vegetation within the site was examined for evidence of nests, adult pairs, birds returning to dense vegetation with food in their beaks, chicks, fledglings, territorial birds, bird dropping stains under branches or any other evidence of breeding birds within the site under examination. Discussions with residents also sought to identify any observations or sightings of unusual or uncommon birds.

Ground Mammals

An examination of the site in September 2018 for protected ground mammals (otters; the joint most highly protected terrestrial Irish mammal (Annex II of the Habitats Directive) and badgers (protected by the Wildlife Act (1976 and 2000) involved a search for any suitably large entrance tunnels, spoil heaps, dung pits, latrines, spraints, scratching points or hairs in the area under scrutiny. The immediate area of the proposed flood relief measures and suitable sites adjoining it were targeted for assessment.

Bats

A dedicated bat detector assessment was carried out from sunset onwards on 12th September 2018 for evidence of feeding and commuting bats and in particular for any emerging bats that may have been roosting within trees on the site. This involved the use of two hand-held ultrasonic receivers (“bat detectors”) to locate and identify bats within and around the site. These detectors were:

- 1) Pettersson D240X heterodyne and time expansion bat detector (D240)
- 2) Echometer 3+ real time expansion detector with viewing screen, SD card recording to WAV files and Garmin GPS attachment for pinpointing signals

The D240 is highly sensitive to bat signals and allows an immediate translation of the signal to an audible, tuneable signal as well as a short-term recording memory that allows the signal to be heard in an earphone played back at 1/10th the speed at which it is emitted and hence within the audible range (e.g. from 45 kHz to 4.5 kHz).

The heterodyne signal is also audible as its frequency is added to a set frequency and the output is within the audible range (when properly tuned less than 1 kHz).

A third monitor, a Songmeter2Bat+, was installed in a tree in Mount Argus Park to assess the bat diversity within the park. The site was examined from 19.20 hours prior to sunset (19.48 hours) \and

for two and one quarter hours (23.05 hours). The site was repeatedly walked, and all mature trees were examined for emerging bats.

The species of bat was determined from signals on the EM3 and D240 within the site at the time of survey and corroborated by analysing with Kaleidoscope 3.1.1 and Batsound 4.2 software.

Botanical results

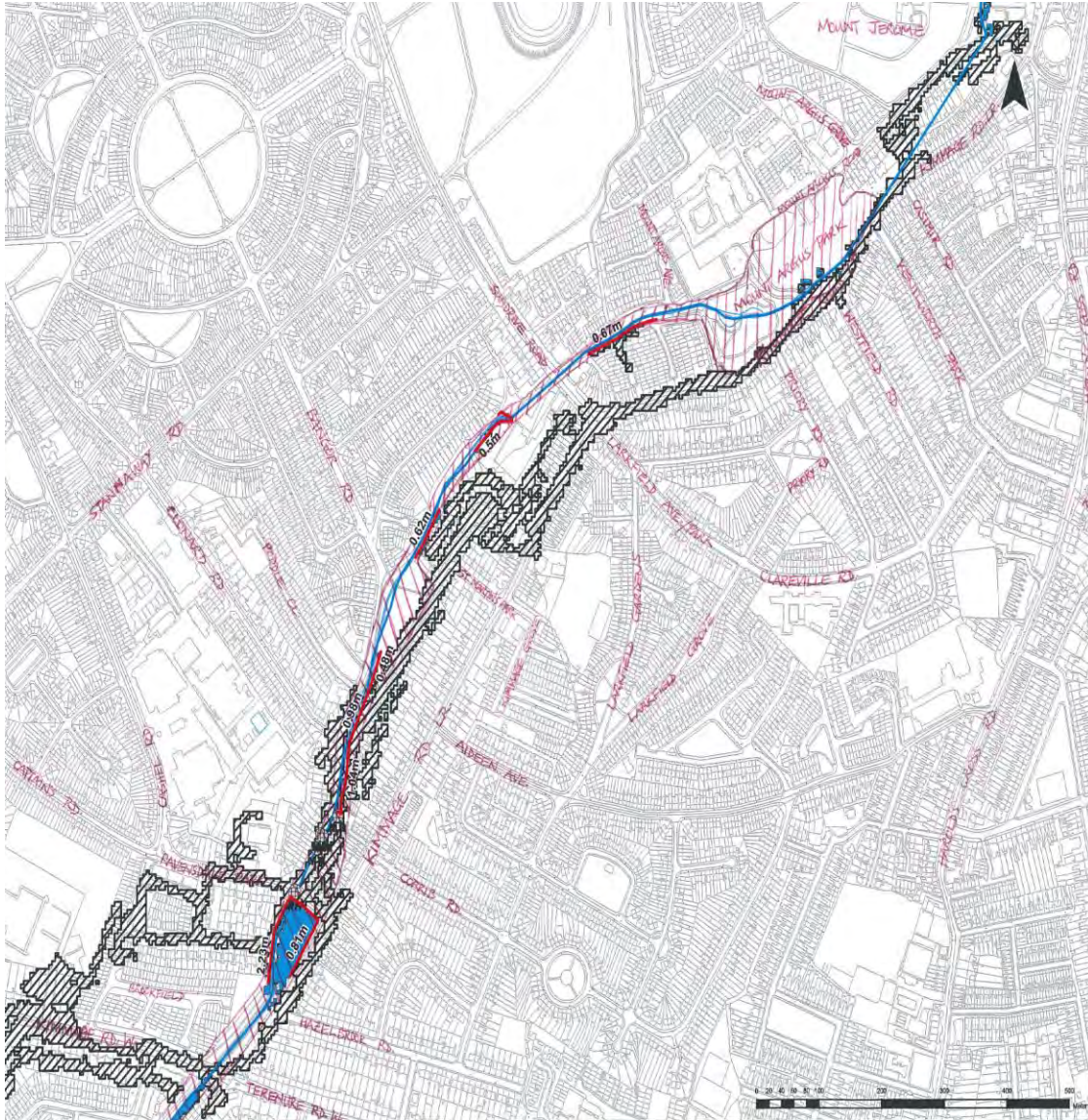

Figure 1. Poddle River flood relief scheme area

The list of recorded habitats within the proposed development site is listed in the table below:

Habitat Name	Habitat Code (Fossitt 2000)
Depositing/lowland rivers	FW2
Marsh	GM1
Dry meadows and grassy verges	GS2
Scattered trees and parkland	WD5
Scrub	WS1

Hedgerows	WL1
Spoil and bare ground	ED2
Buildings and artificial surfaces	BL3

The River Poddle section which was surveyed on this occasion falls into the category of **Depositing / lowland rivers (FW2)**. Depositing conditions cause fine sediments deposit on the river bed. The whole surveyed stretch of the Poddle River is confined by artificially reinforced banks, while part of it flows within a culvert underground.

In the slower sections this habitat grades into **Marsh (GM1)**, with herb vegetation growing in the shallower sections of the watercourse.

The banks are mostly covered by herbs, which leaves the banks bare and prone to erosion in the winter time: *Urtica dioica*, *Heracleum sphondylium*, *Geum urbanum*, *Rumex crispus*, *Rumex obtusifolius*, *Senecio jacobaea*, *Trifolium arvense*, *Taraxacum officinale*, *Hieracium* sp., *Plantago lanceolata*, *Achillea millefolium*, *Epilobium hirsutum*, *Calystegia sepium*, *Cirsium* sp., *Petasites* sp., *Equisetum telmateia*. There are occasional evergreen floor plants: *Hedera helix*, *Asplenium scolopendrium*, *Carex paniculata*. Ornamental garden plants are also occasionally present.

Typical aquatic vegetation includes *Lemna* sp., *Rorippa nasturtium-aquatica* and *Phragmites australis*.

The river and its banks are heavily affected by litter and garden waste.

The river habitat is always of high significance. River Poddle enters the Grand Canal (which is a proposed National Heritage Area) 1 km downstream, which joins River Liffey (a pNHA as well). Therefore, any changes in this habitat may influence the afore-mentioned watercourses. It is important to keep to the best practice while working near the stream.



Figure 2. River Poddle at the Poddle Park.



Figure 3. River Poddle along the Poddle Park street.

The banks are usually steep and accompanied by either **Hedgerows (WL1)** or **Shrub (WS1)**.

Hedgerows are neglected and escaped. They include the following species: *Sambucus nigra*, *Fraxinus excelsior*, *Buddleja davidii*, *Crataegus monogyna*, *Sorbus aucuparia*, *Rubus fruticosus* agg. It is worth stressing that there are also invasive species of shrub growing here: *Prunus laurocerasus* (Cherry laurel) and *Cornus sericea* (Red osier dogwood). Although these species are not subject to restrictions under Regulations 49 and 50 (EC Birds and Natural Habitats), they are highly invasive and should be prevented from spreading.



Figure 2. St. Martin's Drive. Banks covered by scrub.

Hedgerows are an important feature in the urban landscape and provide habitat for many native plants and animals.

They are the remnants of woodland. They are of high local importance due to the low number of similar habitats in the area.

Banks of the less accessible stretches of the river are mostly covered by scrub containing similar species as the hedgerows.

This habitat provides space for biodiversity and is of medium local importance.



Figure 3. Mount Argus Park.

There are three instances of more open situations: Poddle Park in the SW, a green area along St. Martin's Drive in the centre of the site and Mount Argus Park in the NE. In both places a **Scattered trees and parkland (WD5)** habitat was identified.

These areas contain some mature trees. They are important roosting and nesting site for birds and provide habitat for many other vertebrates and invertebrates. Therefore, this element of the parkland is of high local importance.

Red osier dogwood grows in the Mount Argus Park as well and should be prevented from spreading.

Sections of the river near the culvert entrance at the Mount Argus park are occasionally mowed and can be classified as **Dry meadows and grassy verges (GS2)**.



Figure 4. Infrequently mowed grassy verge at the Mount Argus Park.

This area can provide space for plant species which cannot sustain regular mowing and can be a source of food and shelter for wildlife. It is of medium local importance.

There were signs of recent works near the wider section of the river at the Mount Argus park. There is a patch of exposed soil. Similar conditions occur along the River Poddle, where the banks eroded. This habitat can be classified as Spoil and bare ground (ED2). It is a temporary habitat and detrimental to the River habitat as bare banks are unstable. This habitat is of low ecological importance.



Figure 5. Bare ground at Mount Argus Park.

Various concrete structures associated with the embankment, walls and hard surfaces fall into category of Buildings and artificial surfaces (BL3). They are of low ecological significance.

Fauna

Birds

There are a variety of common bird species along the Poddle and within the adjoining green spaces. All of the species noted are common and widespread and included songbirds, gulls and ducks all of which are ubiquitous in Dublin. These included robin, wren, chaffinch, blackbird, song thrush, blue tit, great tit, herring gull, black-headed gull, mallard, rook, jackdaw, hooded crow.

Ground Mammals

There was no evidence of otters, badgers or other protected ground mammals during this examination. Otters may be limited in their use of the river by the repeated sequence of culverting of the river and this would hinder their movement along the river. Otters are unwilling to travel over long distances in areas under bridges where they cannot see an end to cover and the Poddle repeatedly goes under cover in this area. The Poddle connects with the River Liffey within the city centre and it is possible that in this area and upriver they may be active.

There is very little green space associated with the Poddle and this limits the likelihood of badgers within the vicinity of the river. There is also no scope for species such as pine marten in this area.

Bats

Three species of bat were in evidence within this survey. Of these, the most common species was the common pipistrelle. This is the most common species in Ireland and it is found throughout Dublin city. This species is a regular house-dweller and it is probable that the bats noted are present in houses and other buildings relatively close to the Poddle. Soprano pipistrelle activity was also noted at Mount Argus. This species is more strongly associated with water courses and water bodies. The

third species; Leisler's bat, was seen and heard flying over the Park early in the survey period. This bat may avail of buildings and trees and while it is probable that the roost site is a building, it is more often found in trees than the two former species.

No trees were noted as roost sites but several trees within the Mount Argus Park have good to high roost potential and would merit further examination if considered for felling or surgery. No obvious roosts were noted close to the Poddle River and it is unlikely that roosts in buildings would be placed at risk by flood alleviation or relief measures.

Summary

No habitats protected under Annex I of the EU Habitats Directive (92/43/EEC) were recorded within the proposed development site.

None of the recorded plant species are listed in the Flora Protection Order (1999) and The Irish Red Data Book.

No otters or endangered bird species are present within the area within which work would be undertaken for flood relief purposes. Three species of bat are present within the area and there are a small number of trees with roost potential in the Mount Argus Park area that would require further examination if considered for felling or surgery.

The flood relief scheme would require a Screening for Appropriate Assessment given the connection formed by the River Poddle with the River Liffey and consequently Dublin Bay.

References

- Curtis T.G.F. & McGough H.N. 1988. **The Irish Red Data Book 1 Vascular Plants**. Stationery Office, Dublin.
- Department of Environment, Heritage and Local Government. 2009. ***Appropriate Assessment of Plans and Projects in Ireland. Guidance for Planning Authorities'***
- Fossitt, J.A. (2000) **A Guide to Habitats in Ireland**. The Heritage Council
- Oxford Brookes University. 2001. ***Assessment of plans and projects significantly affecting Natura 2000 sites. Methodological guidance on the provisions of Article 6(3) and (4) of the Habitats Directive 92/43/EEC***. European Commission, Environment DG.
- Parnell, J., Curtis, T. (2012) ***Webb's An Irish Flora***. Cork University press



Bat survey area covered along the Puddle

Bat records within the survey area (including below)



Legend

Green paddle Common pipistrelle
Blue paddle Soprano pipistrelle Yellow paddle Leisler's bat

APPENDIX 7-3. DESKTOP RECORDS OF RARE AND PROTECTED SPECIES

Desktop records from the National Parks and Wildlife Service databases

Taxon	Latin Name	Common Name	Location	Latest record	Legal Status	Endangered Status
Flowering plants	<i>Agrostemma githago</i>	Corncockle	Glenasmole, Ticknock, Finglas, River Dodder	1993		Ex
	<i>Anthemis arvensis</i>	Corn Chamomile	River Dodder, Finglas, Custom House Docks	1993		Ex
	<i>Bromus racemosus</i>	Smooth Brome	Glasnevin	1833		R
	<i>Carex divisa</i>	Divided Sedge	North Lotts, East Wall, North Strand	1894	FPO	Ex
	<i>Centaurea cyanus</i>	Cornflower	Glasnevin, Alexandra Road District	1933		Ex
	<i>Cephalanthera longifolia</i>	Narrow-leaved Helleborine	Glenasmole	1970	FPO	VU
	<i>Erigeron acer</i>	Blue Fleabane	Ballinascorney, Templeogue, Finglas, River Dodder	1903		VU
	<i>Galeopsis angustifolia</i>	Red Hemp-Nettle	Old Bawn, Bohernabreena, Dundrum, Three and Two Rock Mountains	1967	FPO	VU
	<i>Groenlandia densa</i>	Opposite-Leaved Pondweed	Grand Canal	2014	FPO	VU
	<i>Hammarbya paludosa</i>	Bog Orchid	Glenasmole, Glencullen	1963	FPO	R
	<i>Hordeum secalinum</i>	Meadow Barley	Finglas, Lotts, Glasnevin	1866	FPO	VU
	<i>Hyoscyamus niger</i>	Henbane	Tallaght - Newtown, Kilmainham, Clontarf	1895		R
	<i>Hypericum hirsutum</i>	Hairy St John's-wort	Drimnagh, Lansdown Valley	1895	FPO	VU
	<i>Kickxia elatine</i>	Sharp-leaved Fluellen	Glasnevin, National Botanic Gardens	1991		VU
	<i>Lolium temulentum</i>	Darnel	James Street, Finglas	1942		Ex
	<i>Misopates orontium</i>	Lesser Snapdragon	Dundrum	1849	FPO	VU
	<i>Orchis morio</i>	Green-Winged Orchid	Talbotstown, Bohernabreena, Milltown, Ticknock, Dundrum	1950		VU
	<i>Orobanche rapum-genistae</i>	Greater Broomrape	Rathfarnham	1726		R
	<i>Papaver hybridum</i>	Rough Poppy	Dublin Port	1934	FPO	EN

	<i>Pseudorchis albida</i>	Small-White Orchid	Glenasmole, Three Rock Mountain	1970	FPO	VU
	<i>Puccinellia fasciculata</i>	Borrer's Saltmarsh-Grass	Sandymount, Ringsend	1906	FPO	R
	<i>Salvia verbenaca</i>	Wild Clary	Glasnevin, Phoenix Park, Rathmines, Dublin Port	1935		R
	<i>Sanguisorba officinalis</i>	Great Burnet	Templeogue	1903	FPO	VU
	<i>Scandix pecten-veneris</i>	Shepherd's-needle	Clontarf, Kimmage	1948		Ex
	<i>Scrophularia umbrosa</i>	Green Figwort	Chapelizod	1990		VU
	<i>Viola hirta</i>	Hairy Violet	Greenhills, Phoenix Park	1990	FPO	VU
Ferns	<i>Diphasiastrum alpinum</i>	Alpine Clubmoss	Cruagh Mountain	1907	HR	Ic
Mammals	<i>Cervus nippon</i>	Sika Deer		1991	WA	N.A.
	<i>Erinaceus europaeus</i>	West European Hedgehog	Tallaght, Terenure, Templeogue, Ballyboden	1975	WA	Ic
	<i>Lepus europaeus</i>	Brown Hare	Ballyboden	1960	WA	N.A.
	<i>Lepus timidus</i>	Irish Hare	Ballyboden	1992	HR, WA	Ic
	<i>Lutra lutra</i>	European Otter	Tallaght	1960	HR, WA	NT
	<i>Martes martes</i>	Pine Marten	Bohernabreena	2005	HR, WA	Ic
	<i>Meles meles</i>	Badger	Tallaght, Ballyboden	1992	WA	Ic
	<i>Mustela erminea</i>	Irish Stoat	Saggart Forest, Tallaght, Ballyboden	1972	WA	Ic
	<i>Nyctalus leisleri</i>	Lesser Noctule	Tallaght	1960	HR, WA	NT
	<i>Plecotus auritus</i>	Brown Long-eared Bat	Tallaght	1960	HR, WA	Ic
	<i>Sciurus vulgaris</i>	Eurasian Red Squirrel	Tallaght	1960	WA	NT
	<i>Sorex minutus</i>	Eurasian Pygmy Shrew	Tallaght	1960	WA	Ic
Amphibians	<i>Lissotriton vulgaris</i>	Smooth Newt	Rathcoole, Churchtown	1972	WA	Ic
	<i>Rana temporaria</i>	Common Frog	Widespread	2011	HR, WA	Ic
Reptiles	<i>Zootoca vivipara</i>	Common Lizard	Tibradden Mountain	1972	WA	Ic

**APPENDIX 7-4. INFORMATION ON THE CONSTRUCTION AND BENEFITS OF
ARTIFICIAL NESTING PLATFORMS**



a million voices for nature



Design of management of rafts

Rafts are a useful way of providing island habitat in areas of deep or fluctuating water levels. Their purpose is to improve breeding success by providing areas safe from flooding, disturbance or predation. Rafts are unlikely to attract terrestrial predators and so are useful where islands would be too close to shore for safety. They also provide wildfowl with loafing spots and are often used as resting places by various bird species during the winter.

Main factors to consider when making a raft

There are many conflicting requirements when constructing a nesting raft.

- The ability to float, preferably with the deck just above the water line.
- The ability to rise and fall easily with the water over the maximum flood range.
- Stability, so that the raft is not tipped or spun by current, waves or wind.
- A dry, sheltered nest site, which does not attract the attention of crows or other avian predators. The nest area must be high enough not to be swamped by storm waves.
- Means of access and some protection from waves and current for young birds.
- Harmonious blending with the surroundings if possible.
- Practical factors e.g. water not excessively deep, lake shore accessible by vehicle, for bringing in boat, raft and materials, and for regular maintenance checks.
- On SSSIs, formal consent may be required from NE, SNH or CCW.

Construction

Although rafts vary in character and design, some basic considerations apply to each.

1. Timber rafts tend to absorb water and sink, although pine or other light wood floats better than heavy timber. In most cases, additional floats must be used if the raft is to last for more than one season.
2. **Flotation blocks:** Small rafts can be floated with plastic 4.5 litre containers. Slightly larger rafts will stay afloat with 22 litre plastic drums. Rafts in the range of 1.2 - 1.8 m in dimension require closed cell polystyrene blocks, polystyrene scraps, airtight metal drums (including old oil drums). Polystyrene is easily held in place and can be adjusted to achieve right buoyancy. It should be packed into strong polythene to prevent it from breaking up and littering the environment. Metal drums need to be weighted so that they do not float too high. The flotation blocks must be thoroughly cleaned before they are brought to the site to prevent pollution. Annual checks and maintenance is important to ensure that the raft remains secure and firm, and that the flotation devices are not disintegrating or leaking.

The RSPB
UK Headquarters
The Lodge
Sandy
Bedfordshire SG19 2DL
Tel: 01767 693690

The RSPB
Northern Ireland Headquarters
Belvoir Park Forest
Belfast BT8 7QT
Tel: 028 9049 1547

The RSPB
Scotland Headquarters
Dunedin House
25 Ravelston Terrace
Edinburgh EH4 3TP
Tel: 0131 311 6500

The RSPB
Wales Headquarters
Sutherland House
Castlebridge
Cowbridge Road East
Cardiff CF11 9AB
Tel: 029 2035 3000

3. **Anchors:** Two anchors are better than one and should be attached to opposite corners of the raft to keep it from swinging in the wind. Anchor to the bottom, not to the shore, to prevent vandalism and to keep rats or weasels from getting to the raft.
 - a. Anchors can be made from breeze blocks, concrete blocks etc. The wire anchor rope should be tied to a short section of chain or to an eye bolt; for large rafts use 19 mm circumference flexible steel wire rope with a 4 ton breaking strain to ensure that the mooring is secure. An anchor weighing about 50 kg is suitable for most rafts. It can be made in a large polythene garden tub half filled with scrap metal or rocks. Wrap one end of an appropriate length of chain around the scrap and fill the tub with concrete. Once the concrete has set, the anchor can be turned out of the mould and the chain bolted to the raft. Three thickness of heavy gauge (24mm) polypropylene rope can be used instead to save money, especially if the raft is in deep water. Where strong winds or currents are likely, several 50kg anchors may be needed to securely hold a 3m x 2m turned raft.

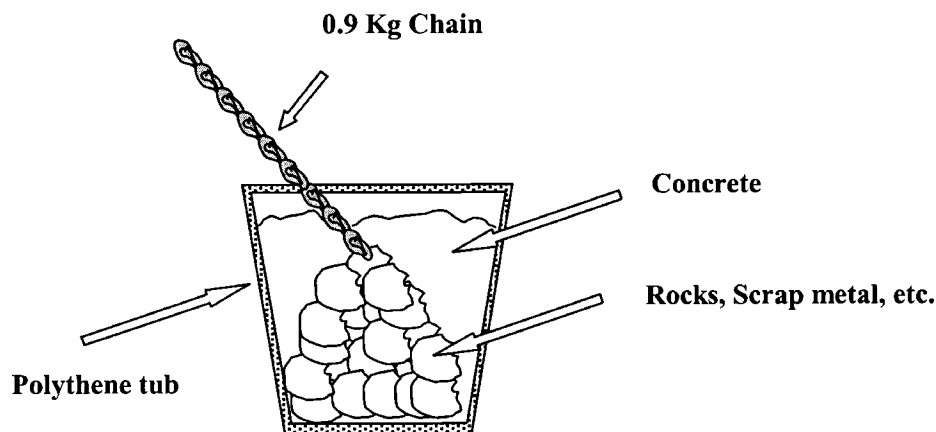

- b. Where one large anchor is too cumbersome to manage, a smaller (e.g. 9 litre) container can be used as a mould and concrete sinkers can be cast with holes through their centres. One sinker can be fastened to the end of the wire and others can be threaded on and allowed to slide to the bottom before fixing the other end of the wire to the raft.
4. Where more than three rafts are to be moored in a string there should be some additional anchor points from the middle rafts to keep the string from sagging before a strong wind and dragging the main moorings.
5. Various nest boxes and duckling ramps can be added to the raft superstructure depending on the species of birds that the raft is intended for. Duck baskets should be at least 1.2 m apart and facing away from each other. They should be tilted slightly upwards at the front and lined with dead grass or some wood shavings. Baskets should be positioned in early January and left until early September, when they should be taken up, cleaned of nesting material and stored under cover.

Species specifications:

1. Wader and tern nesting rafts, in most cases, should be bare of vegetation and covered with a material attractive to the intended nesting species.
2. Wildfowl rafts require more vegetation. Rushes, reeds or small willows are suitable, planted either around the edges or over the deck of the raft leaving pathways to the nest box or central clearing. Plants survive best on raft designs with an open mesh or slatted platform just above the water

line, covered with moisture-holding mulch in which the plants can root and through which they can reach the water.

Some raft models

The area and water characteristics determine the best design for a raft. Some of the designs used on RSPB reserves are described below as a guide.

Simple log or telegraph pole rafts

Logs from nearby felling operations or used GPO poles are often available free and can be used to provide the basis both for simple rafts and more elaborate designs. Without any additional support, the timbers eventually sink low in the water and sprout a floating garden, which should prove to be attractive to nesting wildfowl if the raft is sited in a calm area.

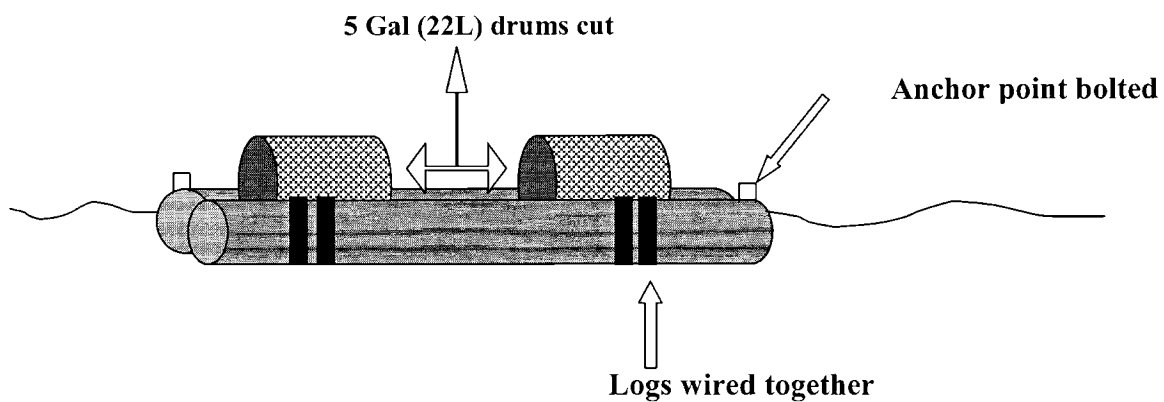

The standard raft

This raft is made of pressure treated (do not use CCA treated) softwood and is 3 meters square. Design includes chick shelters, a re-entry ramp and an optional security fence. Buoyancy is provided by two high-density polystyrene blocks. Raft is anchored to concrete blocks by a chain attached to a marker buoy. It is covered with gravel and rocks, and any plant growth is removed each winter.

Raft platform:

Mainframe: 100x200mm timber, bolted together in each corner through overlapping ends (two upper, two lower), one top inset 150mm to allow for re-entry ramp. Deck 25x150mm planking, laid on and nailed (75mm galvanized nails) to lower mainframe timbers. Sub frame 50x75mm runners to support flotation and strengthen deck, nailed (150mm nails); main flotation holders/deck support 50x100mm runners; sides 25x150mm planking, nailed flush with top of upper mainframe timbers along the lower sides to hold in gravel etc, and flush with the bottom of the mainframe timbers along the upper sides to hold the flotation devices in place.

Buoyancy:

Blocks of 380x600x2700mm high density polystyrene foam, painted (optional) with BP Aquaseal 44 bituminous paint (as suitable for use inside cold water tanks) to water seal and strengthen the polystyrene; two optional straps per float block, 1,420mm strips of polystyrene webbing (or 50mm chair webbing as a temporary measure, eg during launching) with eyelet holes for nailing to frame. Once in the water, the weight of the raft is sufficient to hold the polystyrene in place without any additional fixings, even in extreme conditions.

Mooring:

Mooring ring bolted through center of mainframe timber (bolt fixed with two nuts so that it can swivel freely), connected preferably to a chain or a 20mm diameter hawser-lay polypropylene rope (which will not rot, but can be chafed), with hard eyes and shackles each end. Tether a 30-inch circumference marker buoy to the raft end of the chain or rope with a length of polypropylene rope to allow the raft to be detached, without having to pull up or lose the anchor.

Anchor:

Multiple small weights (up to 1m³ concrete as a total) for ease of transport. Four buckets 250mm high by 300mm diameter of concrete, eyebolt set in centre; weights connected in pairs by shackles to 300mm lengths of chain; fixed to mooring by placing two pairs of weights together with the connecting chains forming a cross, and attaching the mooring rope shackle to the point where the chains cross. Exposed sites where wind and waves are strong may require more anchor weights.

Shelters (to protect from rain):

These comprise 1m long 25x150mm planks located in opposite corners, nailed flat onto end of upper mainframe timber, side plank and 50x75mm end block.

Gravel covering:

Preferably of 15mm-25mm gravel with larger pieces and rocks to provide shelter, and give sufficient weight to push running board down to water level.

Re- entry system (for chicks falling overboard):

These are located on opposite (lee) side of raft to the mooring ring: running board 3m, 25x150mm plank nailed to bottom of the two lower mainframes. Ramp (1.5m, 25x150mm plank) sloping up to top corner of mainframe, supported by up stand, nailed. Block gap under raft behind ramp with 25x150mm skirt plank.

Optional removable security fence:

These comprise four frames 230mm by 0.3m, made from 50x50mm planks covered with 25mm chicken wire, bolted along each side and fixed at top corners.

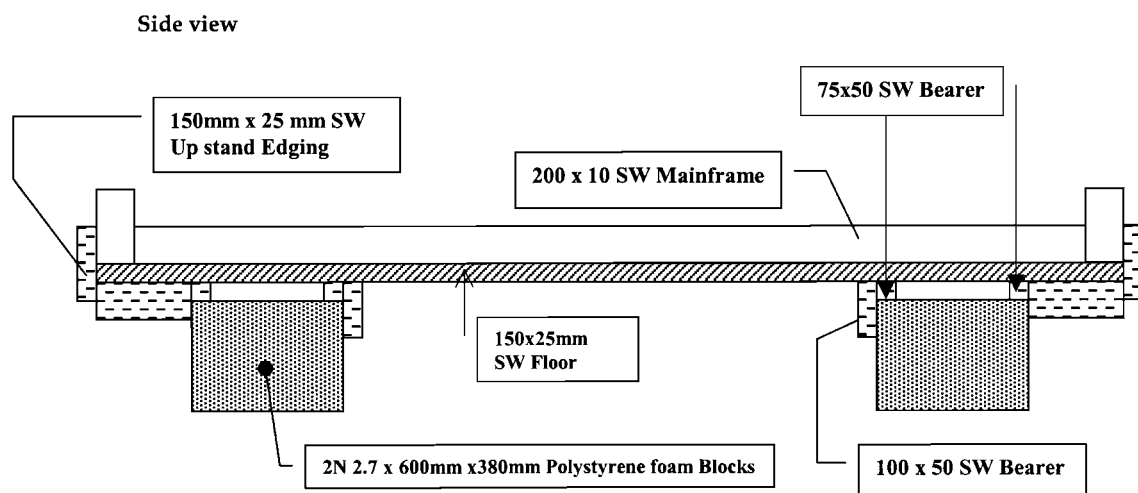

View from above

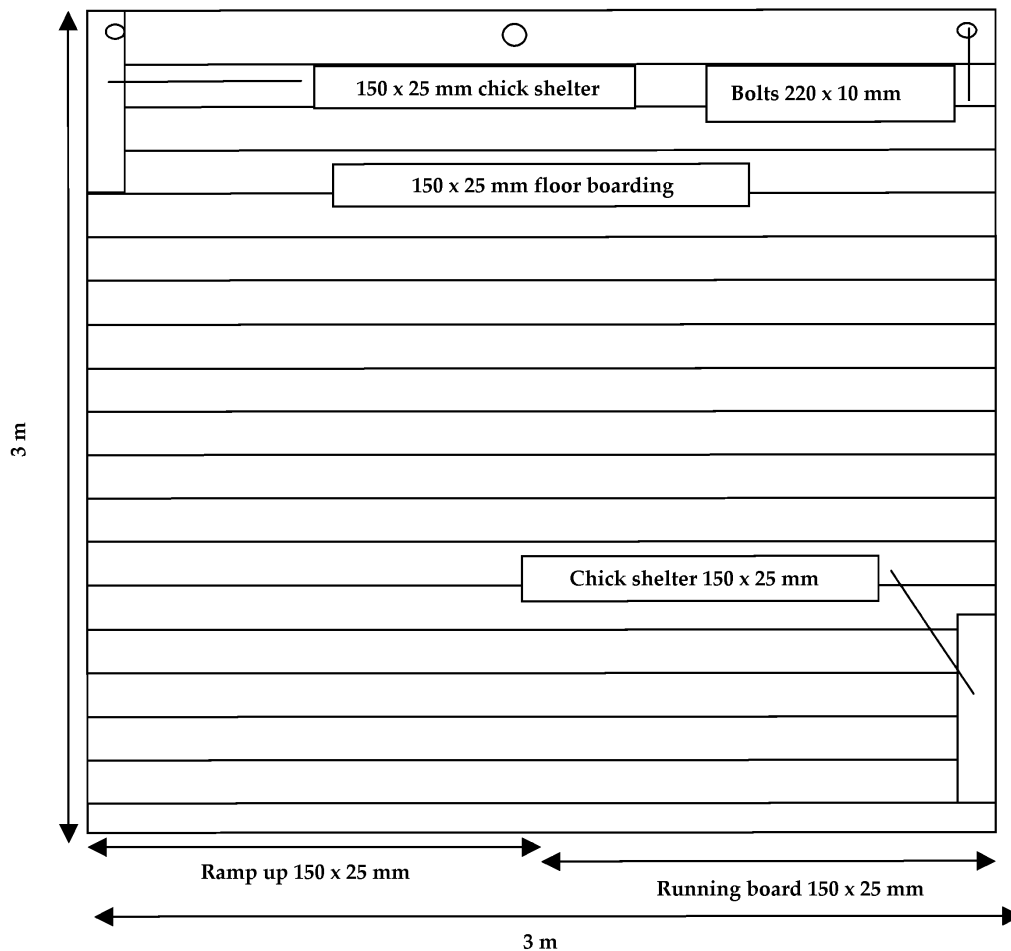

A floating wildfowl nest for use on rivers

This design, successfully used on the Ray, near Oxford, is intended to overcome the problems posed by strong currents, which make it difficult for wildfowl to nest successfully on rivers. Chick survival is best where the floating nest is sited on a quiet backwater with gently sloping banks so that, when a chick leaves the nest, it can get to the shore and climb out despite the current.

1. Drive a suitable length of 50mm diameter steel pipe into the riverbed to provide an anchor pole on which the floating nest can rise and fall with changes in water level.
2. Cut out a circular platform from marine plywood and cut a hole in its centre so that it fits over the anchor pipe.
3. Screw three boards to the circular plywood piece, so that they form an equilateral triangle to make a frame underneath the platform for the floats.
4. Strap three 4.5 litre plastic or metal tins to the triangular frame, one each side. If metal tins are used, they should be well painted with bitumen paint and coated inside with a spoonful of old engine oil before capping.
5. Attach three metal struts, evenly spaced, to the edge of the platform, joined at the upper end to a ring that fits over the anchor pipe. This upper ring, with the hole in the platform, forms the bearing on which the nest rises and falls on the pipe.

6. Fasten a conical covering of light but firm netting around the outside of the strut assembly, and use vegetation to provide some shelter. Leave a 150 mm diameter entrance on one side.
7. Slide the platform down over the pipe. If it tends to spin in the current, attach a rudder to the floats to keep it properly orientated. The entrance hole should be arranged to face the nearest bank.

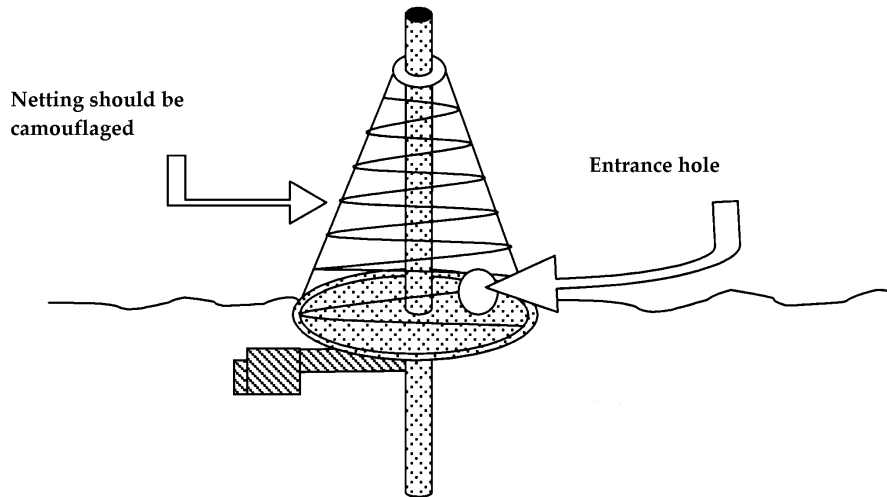

A square raft

This design is popular and has proved to be highly effective and weatherproof. Similar structures are in use in many reserves.

- a. Construct a framework of 25 x 150mm boards or similar. Nail the flooring across the top of the frame leaving the margins open to take vegetation and nail duckling ramps to one end of the raft. Use galvanized nails since they do not rust.

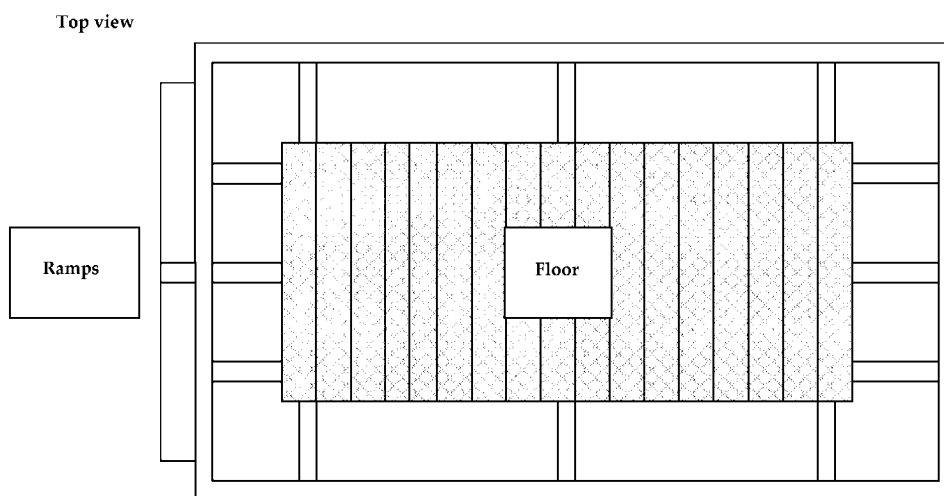

- b. Turn the raft over. Staple close-mesh galvanized wire netting across the bottom of the raft, leaving the central part free to hold the flotation blocks.
- c. Place 150mm thick polystyrene blocks in the uncovered centre of the frame. Hold the polystyrene in place with diagonal boards nailed across the frame.

Underside view

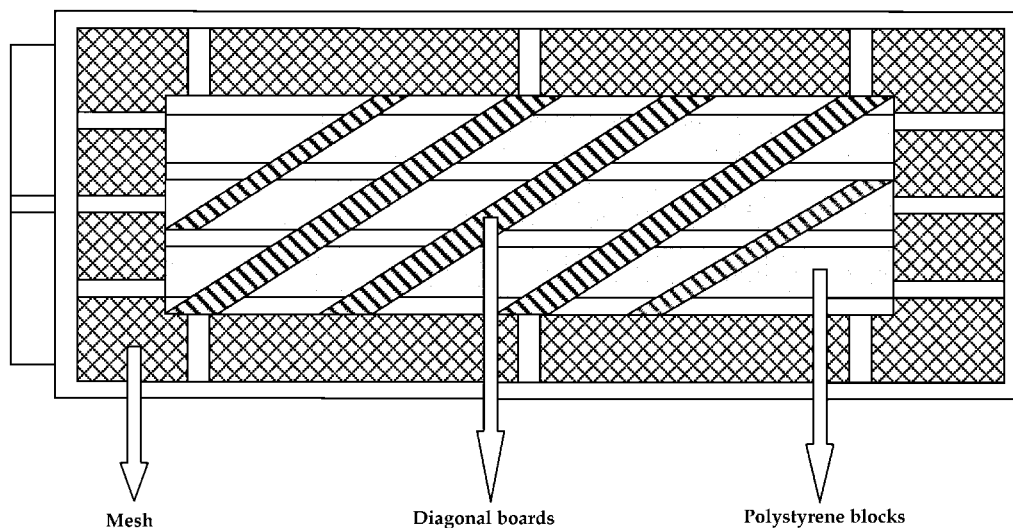

- d. Turn the raft right way up. Cut out blocks of rush, willow etc. to fit into the margins of the frame. Fit anchor bolts to two opposite corners. Fix a nesting box or basket if required. You can cover the raft with some gravel. Finally, tow the raft into the position and anchor it firmly.

A heavier variation:

The raft described below is very successful when attracting terns to nest. Bare shingle is required for the nesting, but a completely exposed raft results in high chick mortality. At about one week old, tern chicks leap overboard at the slightest disturbance. This can be prevented by providing them with small shelters to hide underneath.

1. Drill the sleepers as indicated in the diagram, using a brace and a bit, and bolt them together with eight 250mm coach bolts. Drill and fix anchor bolts in the end sleepers.
2. Drill and bolt the cross members to the side sleepers. These are required to make a rigid structure and to resist the upward pressure of the floats.
3. Nail the side battens into position; these help hold the shingle in place.
4. There are two ways to floor the raft. One is to trap plastic-coated chain link fencing, covered in heavy-duty polythene, under the cross braces. Staple the fencing firmly to the sleepers. Alternatively, nail old garage doors or other suitable sturdy timber to the cross members and spread the flooring with a layer of concrete to help keep the shingle in place.
5. Float the raft. Unless you have mechanical help, placing approximately 0.8 cubic metres of polystyrene blocks under the raft for flotation will require a number of water-hardy volunteers.
6. The amount of polystyrene needed varies with the weight of the raft so trials are necessary. Provide some extra flotation to compensate for the shingle, which is added afterwards. The polystyrene stays in place between the sleepers due to its buoyancy and should not need fastening.
7. Spread a layer of shingle over the flooring.
8. Fix ramps or walls to the rafts sides, place a shelter on it, tow it into position and anchor it by means of bolts in the end sleepers.

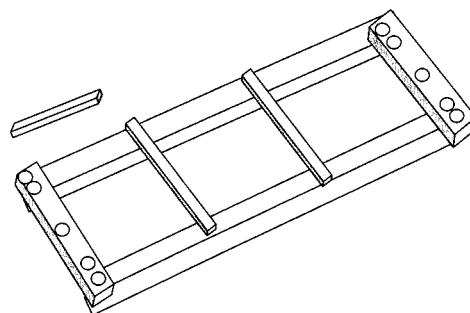

Welded Rafts

These two models were designed for the specific needs of a particular area. They require a great deal of skills and therefore are only suitable if none of the previous ones can be used. The designs shown have proved to have an estimated life of at least 12 years with minimal maintenance. These types depend on availability of suitable welding equipment and skills, and sheet-metal float tanks used by gravel companies for ferrying electrical equipment around wet pits.

Type A

Weld together three float tanks and attach a rim of logs with welded metal straps. To moor the raft, fix a wire anchor rope to a 50 kg scrap iron or concrete anchor. This simple but strong raft gives a surface area of 6.7 square metres. It successfully attracts ducks and geese, but has two disadvantages. It is so buoyant that the nest floats at least a foot above the water so that, unless a ramp is attached to help them, once the chicks leave the raft they cannot return. Soil ultimately dries out or is dislodged and must be replaced at intervals along with fresh vegetation.

Type B

This rather elaborate design features a semi-flexible welded frame, which makes the raft very durable in exposed conditions. The float tanks are the same size as in the previous design; the sleepers are topped with a grid that holds nesting cover.

Construction:

- Weld the frame together and to the float tanks. Weld two anchor bolts to opposite corners.
- Manoeuvre the completed frame into the water.
- Slide the sleepers into position. Leave gaps between the pairs of sleepers so that plant roots can reach the water.
- Cover the top of the frame's central section with narrow-mesh galvanized metal.
- Fix the nesting boxes on top of the floats
- Cover the mesh with mulch or soil and suitable plants. Plant up the nesting boxes.
- Tow the raft into position and anchor from the anchor bolts.

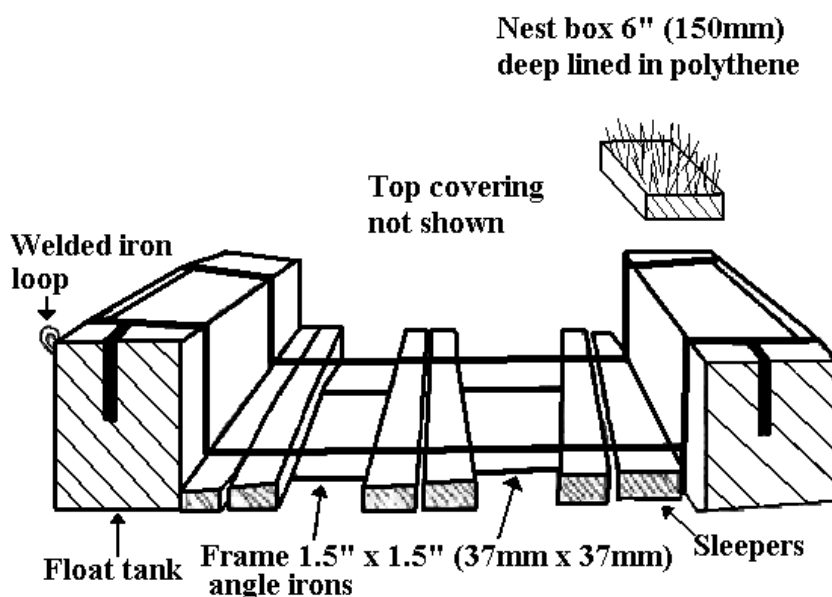

Creation and Management of Artificial Nesting Sites for Wetland Birds

Neil D. Burgess and Graham J. M. Hiron

Royal Society for the Protection of Birds, The Lodge, Sandy, Bedfordshire
SG19 2DL, U.K.

Received 1 December 1990

Since 1963 about 270 islands and 40 rafts have been constructed and managed in Britain by the Royal Society for the Protection of Birds, mainly at its wetland reserves. These structures are primarily aimed at providing secure breeding sites for terns, waders, gulls, wildfowl and divers, including nine species of particular conservation importance in Britain. Use of islands and rafts by different breeding species is dependent upon their vegetation cover and geographical location. Bare shingle, or sparsely vegetated islands and rafts, attract the most breeding species in southern coastal locations (up to 20 species), including five species of conservation importance, namely Sandwich tern (*Sterna sandvicensis*), little tern (*Sterna albifrons*), avocet (*Recurvirostra avosetta*) and, occasionally, Mediterranean gull (*Larus melanocephalus*) and roseate tern (*Sterna dougallii*). Similar unvegetated or sparsely vegetated islands on the coast in the north, or inland in the north or south of Britain, support few breeding species, and none of conservation importance. The composition of the bird assemblage breeding on well-vegetated islands and rafts in Britain (up to 20 species) is less influenced by geographical location, but species of conservation importance such as pochard (*Aythya ferina*) are found mainly in the south, and common scoter (*Melanitta nigra*), red-throated diver (*Gavia stellata*) and black-throated diver (*Gavia arctica*) exclusively in Scotland.

Keywords: islands, rafts, breeding birds, Great Britain.

1. Introduction

Islands and rafts have been created by the Royal Society for the Protection of Birds (RSPB) at wetlands primarily because many bird species select them as breeding and loafing sites in preference to mainland locations with similar habitat features (Axell, 1982; Brookes, 1981; McIntyre and Mathisen, 1977; Giroux, 1981; Hill, 1984*a,b*; Street, 1989; Swift, 1982). Artificial islands and rafts are probably chosen as nesting sites because they provide greater protection from mammalian and avian predators which have difficulty gaining access to them (Hill, 1984*a,b*; Giroux, 1981). Such artificial nesting sites have particular value for bird conservation in Britain because they can attract several priority breeding species (see Bibby *et al.*, 1989; NCC/RSPB, 1990).

Moreover, rafts can be used on deep waterbodies, or ones with fluctuating water levels, to attract breeding birds in areas where suitable natural nesting sites are not available.

An additional factor favouring the creation of islands and rafts on nature reserves is that they can be used to concentrate breeding and loafing waterbirds in front of hides. This enables reserve visitors to obtain good views of birds, sometimes including secretive species which they would otherwise have difficulty in seeing.

This paper briefly describes the creation of islands and rafts by the RSPB, reviews the management they have received to attract and maintain populations of breeding birds, in particular priority species, and summarizes their conservation benefits. The data are mainly based on replies to a questionnaire from 10 RSPB reserve wardens in England, one in Wales and six in Scotland. Additional information was obtained by personal communication with wardens and RSPB regional offices throughout Britain.

2. Construction of artificial nesting sites

2.1. ISLANDS

Nesting islands on RSPB reserves have been constructed in two basic ways:

1. by dumping locally derived material into shallow water until it protrudes above the water surface (deposit islands); and
2. by leaving some island-shaped mounds when excavating an area; these remain proud of the water surface when the area is flooded (remnant islands).

The surface areas of the islands so produced have varied between 5 m² and 2000 m², with most being 30–500 m² in extent. Usually, they are isolated by stretches of open water at least 2 m wide and 0.2 m deep to make access by predators more difficult. The cost of creating a deposit island varies between £1.00 and £2.00 per m² of surface area in 1–2 m deep waterbodies. The cost of a remnant island is contained within the costs of excavating a waterbody at a wetland reserve.

Some of the islands created by the RSPB have been in existence for over 25 years (e.g. Minsmere in Suffolk), with the only damage arising from wave erosion of the island edges. However, erosion can be a more severe problem, and in the most severe cases (e.g. Dungeness in Kent) all island material protruding above the water surface can be removed. In locations where wave erosion is likely, special precautions must be taken during island construction, especially if they are built out of unstable material such as shingle or gravel. Methods used to overcome or reduce erosion have included:

1. constructing wave deflecting structures around the islands;
2. producing a 1 in 10 sloping base to the island, which is relatively stable under all conditions;
3. planting emergent vegetation around the island, especially on the side of prevailing wind;
4. covering the island with plastic netting;
5. piling stakes into the windward side of the island;
6. situating the island in a sheltered bay where it is less subject to wave damage;
7. surrounding the island by a beach of large pebbles.

2.2 RAFTS

Two main types of raft have been constructed by the RSPB: (a) shingle-surfaced wooden rafts with polystyrene floats, and (b) synthetic rafts surfaced or filled with local vegetation which aim to look as much like the natural surrounding vegetation as possible (see Burgess and Becker, 1989, for design details). These two types of rafts are aimed at attracting terns, and wildfowl and divers, respectively.

The surface area of the rafts constructed has been between 1 m × 1 m and 3 m × 3 m. The rafts have cost between £100 and £300 each, depending on their size and complexity. Rafts need to be firmly anchored to the substrate to prevent them floating away (see Burgess and Becker, 1989). In windy locations it may be difficult or impossible to prevent the raft drifting or breaking loose of its moorings during the winter; hence, it is advisable to either remove the rafts completely, or move them to a more sheltered location during the winter.

3. Management of surface conditions to attract priority breeding birds

Many years of management experience on RSPB reserves has identified the surface conditions required to entice birds of high conservation priority (Bibby *et al.*, 1989; NCC/RSPB, 1990) to breed on artificial islands and rafts.

On the coast, management has been directed at the following key breeding species: avocet, Sandwich tern and little tern; all of which are known to prefer sparsely vegetated or bare surfaces for nest sites (see Axell, 1977). Other priority species with similar requirements are roseate tern and Mediterranean gull.

In freshwater situations in England, the key breeding species which can be attracted is pochard. In Scotland, the key breeding species are red-throated and black-throated diver (Campbell and Mudge, 1989), with common scoter also having similar habitat requirements. All these species are known to favour nesting in well-vegetated situations.

3.1. SPARSELY VEGETATED ISLANDS/RAFTS

Two main methods are used to produce and maintain sparsely vegetated conditions on artificially created islands or rafts.

3.1.1. *Shingling*

To create an unvegetated shingle island, two or three layers of thick plastic sheeting (often old fertilizer bags) are placed on the island substrate. A 10–30 cm layer of 6–18 mm diameter gravel and finer sand is then added on top of the plastic to provide the material on which birds can nest (Figure 1). The addition of shingle to an island occupies around 1 man day per 5 tonnes of shingle if work is done from a boat (equal to *c.* 10 m² of island surface). The main benefit of placing shingle over plastic-sheeting is that it permits rapid run-off of rainwater from the island and also restricts the availability of ground water to colonizing plants. As a consequence, such islands remain largely free of all but the most desiccation-resistant plant species for several years after their creation. The management required to keep these islands attractive to breeding birds comprises only a couple of hours hand weeding or strimming of small plants per annum.

Shingled rafts generally have a 10–20 cm thick layer of shingle over the raft surface, with side boards to retain this material. The shingle may have to be replaced following severe winter weather but otherwise such rafts require little maintenance.

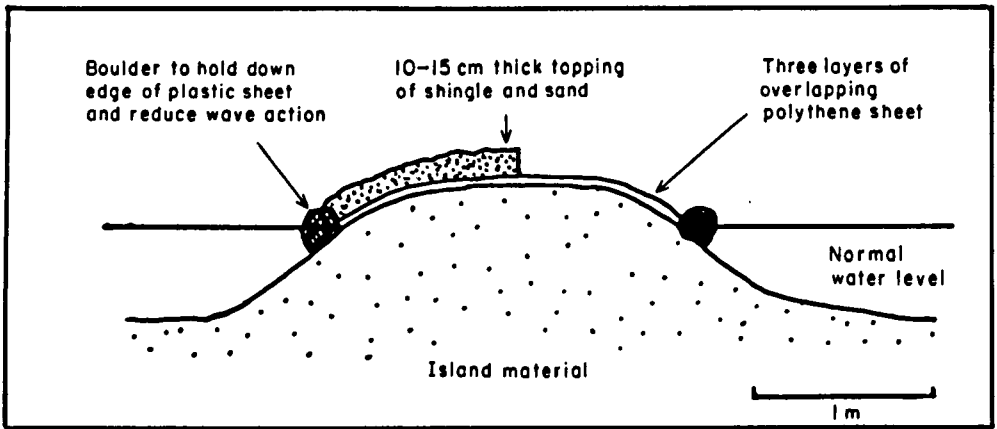

Figure 1. Generalized design of a shingle/sand covered, sparsely vegetated island with a plastic underlay.

3.1.2. Vegetation removal

In order to maintain bare conditions on islands lacking a layer of subterranean plastic, the majority of the annual vegetation growth must be removed each year, generally in the spring and autumn. Methods which have been used to remove vegetation include hand pulling, rotovating, ploughing, flooding over winter, herbicide sprays or a combination of methods (Table 1). Mechanical methods are less labour intensive than manual ones, but manual vegetation removal is often necessary on the smallest islands. In general, several man days are needed per annum to maintain a single 100 m² island. Regardless of the method, vegetation management must be repeated each year otherwise the island quickly becomes overgrown with dense vegetation, rendering it unattractive to priority bird species which need bare conditions.

On sparsely vegetated rafts, any vegetation is normally removed by hand weeding, but this is rarely a problem as rafts do not provide particularly suitable conditions for colonization by wetland plants.

3.2. WELL-VEGETATED ISLANDS/RAFTS

If islands receive little management after their construction, they are rapidly colonized by wetland and ruderal plants (Figure 2), which provides suitable breeding habitat for wildfowl and divers. Alternatively, an island may have turves of the local vegetation placed over its surface to speed the colonization process. For vegetated rafts, clumps of local wetland vegetation are often used to produce the surface and hence provide as natural a finish as possible.

If the vegetation on islands is never managed, woody species such as alder (*Alnus glutinosa*) and, especially, willow (*Salix* spp.) will eventually colonize. This colonization will reduce their attractiveness for breeding waterbirds as the herb layer which forms the nesting substrate is eventually shaded out. On most RSPB reserves, the vegetation of well-vegetated islands is cut at the end of the breeding season (August/September) to retard the growth of woody species, checking the natural succession and retaining a herb layer in which wildfowl and divers prefer to nest.

TABLE 1. Management operations on islands at selected RSPB reserves

	Reserves										
	Blacktoft Sands	Ken/Dee	Leighton Moss	Loch Strathbeg	Havergate Island	Vane Farm	Sandwell Valley	Strumpshaw Fen	Titchwell Marsh	Minsmere	Snettisham
1. Sparsely vegetated islands											
Operation											
Weeding in autumn	+	+	+		+		+			+	+
Weeding in spring	+		+		+					+	
Cutting in winter								+			
Flooding during winter	+		+		+				+		
Chemical sprays											
Adding shingle	+		+	+	+		+			+	+
Burning	+				+						
Cutting in autumn	+										
Digging in autumn/winter	+		+							+	
Strimming	+	+			+					+	
2. Well-vegetated islands											
Weeding in autumn			+								
Cutting in winter											
Winter flooding					+			+			+
Herbicides	+		+								
Burning	+				+						
Cutting in autumn (vegetation removed)	+		+		+					+	
Strimming		+			+						+

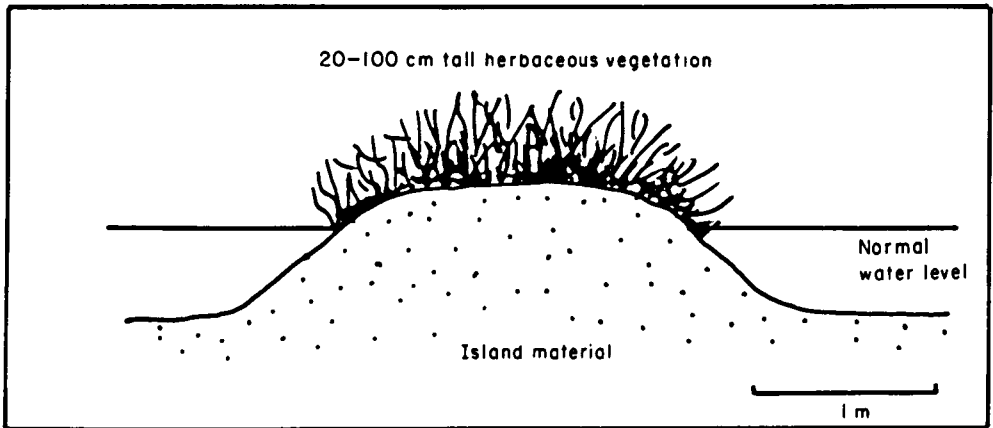

Figure 2. Generalized profile of well-vegetated islands.

4. Use of artificial sparsely and well-vegetated islands and rafts by breeding birds

Thirty species of bird have been recorded breeding on islands artificially created by the RSPB (Table 2). The number and type of birds varies markedly, depending on the vegetation cover of the island/raft and its geographical location in Britain.

For example, the 20 species recorded as breeding on sparsely vegetated islands/rafts at southern coastal reserves are mainly waders, terns and gulls. These include several species of conservation importance, namely, avocet, little tern, Sandwich tern, roseate tern and Mediterranean gull. In comparison, the 20 species recorded breeding on well-vegetated islands in the north and south, and at inland reserves in the north comprise mainly wildfowl. The species of conservation importance breeding on these islands/rafts are pochard, common scoter, red-throated diver and black-throated diver (Table 2).

Sparsely vegetated islands at coastal reserves in the north, or at inland (freshwater) reserves in the north and south, only support between nine and 10 breeding species, and none of conservation importance. However, well-vegetated islands at coastal reserves and inland in the south support between 13 and 19 species, but apart from pochard, species of particular conservation importance are absent (Table 2).

4.1. EXAMPLES OF THE USE OF ARTIFICIALLY CREATED SPARSELY VEGETATED OR BARE ISLANDS AND RAFTS

In the south of Britain, sparsely vegetated islands and rafts have been mainly created to provide breeding habitat for avocet and terns. For example, at Minsmere on the Suffolk coast, the population of breeding avocet has increased as a larger number of suitable island nesting sites have been provided [Figure 3(a)]. Also, on the Suffolk coast at Havergate Island, the preference of avocets for island nest sites was demonstrated when, following the creation of 25 shingled islands, most of the birds ceased to breed on the lagoon margins and moved to the islands [Figure 3(b)]. Similarly, after the creation of islands in shallow brackish coastal lagoons at Titchwell Marsh on the north Norfolk coast in 1982, and their annual management to maintain a vegetation free surface, avocets colonized in 1984 and rapidly increased in numbers to 45 pairs in 1989 [Figure 3(c)].

Artificially created sparsely vegetated islands are also attractive to breeding terns and some gulls. For example, at Dungeness in Kent, the creation and management of *c.*20 shingle islands in a 46 ha lagoon has attracted up to 350 breeding pairs of Sandwich and common terns [Figure 3(d)], up to 1000 pairs of black-headed gulls and, occasionally, a few pairs of common gull (*Larus canus*), Mediterranean gull and roseate tern.

At Minsmere, shingle islands have also been attractive to little terns. Some of the islands in the coastal lagoons have been newly resurfaced with shingle over the past few years and have attracted these terns in larger numbers than were previously present [Figure 3(e)]. Rafts covered by a fine layer of shingle have also attracted breeding population of common terns to areas where they were previously absent [Figure 3(f)].

4.2. EXAMPLE OF THE SUCCESS OF ARTIFICIALLY CREATED WELL-VEGETATED ISLANDS AND RAFTS

The provision of densely vegetated islands at reserves such as Strumpshaw Fen in the Norfolk Broads, Minsmere, Titchwell Marsh, Dungeness and Blacktoft Sands on Humberside has attracted breeding populations of gadwall (*Anas strepera*), shelduck (*Tadorna tadorna*), pochard and teal (*Anas crecca*) where previously they were either absent or present in very low numbers. In recent years, vegetated rafts floated on to Scottish lochs have been successful in attracting nesting red and black-throated divers and common scoter (Campbell and Mudge, 1989).

5. Discussion and conclusions

Sparsely vegetated islands created at inland waterbodies, or on the coast in the north of Britain, are of lesser importance to the conservation of priority British breeding birds than similar islands at coastal reserves in the south and east. Well-vegetated islands have similar value for the conservation of non-priority species throughout most of Britain, but have attracted three priority species in Scotland.

As well as their value for nesting birds, islands and rafts also provide a safe preening, loafing and roosting position for migrant and wintering waders and wildfowl. In Britain as a whole, 25 species of wader and 14 species of wildfowl have been recorded using artificially created islands and rafts on migration, with the highest number of species recorded near the east coast. Similarly, 14 species of wader and 14 species of wildfowl have been recorded using islands and rafts in the winter (Burgess and Becker, 1989). The value of shingle-covered islands to loafing waterfowl has been discussed by Street (1989).

In conclusion, islands and/or rafts are an inexpensive way of increasing the conservation interest of most waterbodies. If they are in a suitable geographical location and managed appropriately, they can attract priority birds to breed.

Data used in this paper were supplied by RSPB wardens throughout Britain. Valuable comments on a draft were received from Dr Gareth Thomas and Dr James Cadbury. Neil Burgess gratefully acknowledges his contract from the Ecology Department at the RSPB.

References

- Axell, H. E. (1977). *Minsmere: Portrait of a Bird Reserve*. London: Hutchinson.
- Axell, H. E. (1982). Establishment and management of an artificial brackish lake with nesting islands at Minsmere, England. In *JUCN/IWRB, Managing Wetlands and their Birds* (D. A. Scott, ed.), pp. 143–146. Slimbridge: International Wildfowl Research Bureau.

Lapwing	+										+						+		+		
Oystercatcher	+										+						+		+		
Ringed plover	-										-						-		+		
Avocet	-										-						-		+		
Little ringed plover	+										+						+		+		
Redshank	-										-						-		+		
Common gull	-										-						-		+		
Mediterranean gull	+										+						+		+		
Black-headed gull	+										+						+		+		
Common tern	+										+						+		+		
Sandwich tern	-										-						-		+		
Little tern	-										-						-		+		
Roseate tern	-										-						-		+		
Total species	20	10	13	9	16	11	19	20													
No. waders	3	4	2	5	2	2	4	6													
No. terns	1	1	1	1	0	1	2	4													
No. gulls	1	1	1	1	1	1	1	4													
No. wildfowl	11	0	7	1	9	4	9	5													
No. divers	2	0	0	0	0	0	0	0													
No. other waterbirds	2	2	2	1	4	3	3	2													

† Islands were defined as coastal if they were within 10 km of the sea, and north if they were north of a line between Liverpool and the Humber.

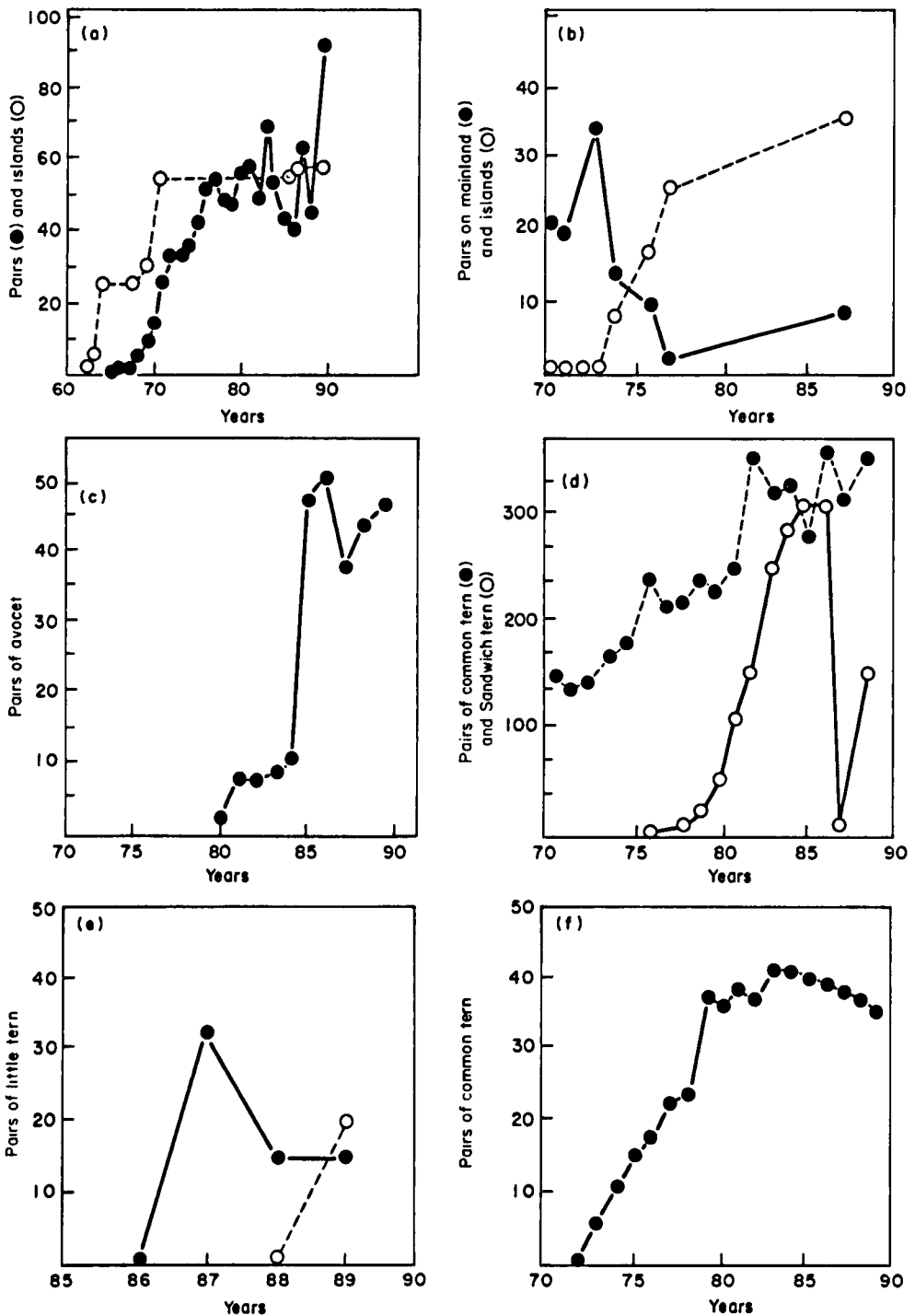

Figure 3. Breeding populations of avocets and terns breeding on sparsely vegetated or bare islands and rafts at various RSPB reserves. (a) Breeding numbers of avocets at Minsmere on the Suffolk coast: from 1960–1989 (—●—); and the number of nesting islands (—○—). (b) —●—, breeding numbers of avocets nesting on the mainland; and —○—, islands at Havergate Island on the Suffolk coast, following the creation of 25 shingled islands in 1974. (c) Breeding numbers of avocets at Titchwell Marsh on the North Norfolk coast from 1970–1989, following the completion of brackish lagoons and nesting islands in 1984. (d) —●—, breeding numbers of common; and —○—, Sandwich terns at Dungeness in Kent, following the construction of a coastal lagoon with nesting islands from 1969 onwards. (e) Breeding numbers of little tern following shingling of islands at Minsmere: —●—, island 65 shingled in winter 1986/1987, and —○—, islands 59 and 60 shingled in 1988/1989. (f) Breeding numbers of common terns on shingled rafts located in old sewage lagoons at Rye House Marsh in Hertfordshire between 1972 and 1989.

- Bibby, C. J., Housden, S. D., Porter, R. F. and Thomas, G. J. (1989). Towards a bird conservation strategy. *RSPB Conservation Review* 3, 4–8.
- Brookes, A. (1981). *Waterways and Wetlands*, revised edn. London: British Trust for Conservation Volunteers.
- Burgess, N. D. and Becker, D. (1989). The creation and management of islands and rafts on RSPB reserves. RSPB Management Case Study. Unpublished.
- Burgess, N. D., Hirons, G. J. M. and Sorensen, J. The creation and management of coastal lagoons at Minsmere, Suffolk. RSPB Management Case Study. Unpublished. (In press).
- Campbell, L. H. and Mudge, G. P. (1989). Conservation of black-throated divers in Scotland. *RSPB Conservation Review* 3, 72–75.
- Giroux, J. F. (1981). Use of artificial islands by nesting waterfowl in southeastern Alberta. *Journal of Wildlife Management* 45, 669–679.
- Hill, D. A. (1984a). Factors affecting nest success in the mallard and tufted duck. *Ornis Scandinavica* 15, 115–122.
- Hill, D. A. (1984b). Clutch predation in relation to nest density in mallard and tufted duck. *Wildfowl* 35, 151–156.
- McIntyre, J. W. and Mathisen, J. E. (1977). Artificial islands as nest sites for common loons. *Journal of Wildlife Management* 41, 317–319.
- NCC/RSPB. (1990). *Red Data Birds in Britain* (L. A. Batten, C. J. Bibby, P. Clement, G. D. Elliot and R. F. Porter, eds). Calton: T & AD Poyser.
- Street, M. (1989). *Ponds and Lakes for Wildfowl*. Fordingbridge: The Game Conservancy.
- Swift, J. A. (1982). Construction of rafts and islands. In *IUCN/IWRB, Managing Wetlands and their Birds* (D. A. Scott, ed.), pp 200–203. Slimbridge: IWRB.



(<http://claregalway.info>)



Translate

- EN
- GA
- PL

The community-curated website for Claregalway

Search

Swan Success in Oranmore

Posted May 28, 2015 by (<http://claregalway.info/author/josettefarrell/>) Jessica Thompson, Galway Independent (<http://www.galwayindependent.com/>) in News (<http://claregalway.info/category/nuacht/news/>).

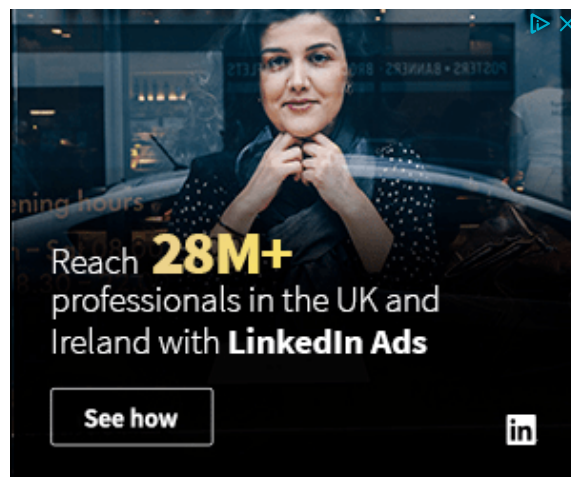

After eight years of losing their nest to tides, a pair of swans have successfully hatched five cygnets in Oranmore, thanks to a special man-made floating raft. The raft is a joint project between Conservation Volunteers Galway and Oranmore Tidy Towns and is led by GMIT's Peter Butler.



(<http://claregalway.info/wp-content/uploads/2015/05/Swan-nest.jpg>)

Swan and cygnets on the raft at Oranmore. Photo by Joe O'Shaughnessy via Connacht Tribune.

“I moved to Oranmore last year and this time last year, I noticed the swans building a nest on what used to be a mill race—it’s a sort of small island alongside the bridge,” Peter explains.

Unfortunately, the tide washed that nest away and he was informed by the locals that this had been going on for years. So he set about researching solutions to the problem.

“The obvious answer was a floating raft that they could nest on. They would be common in the canals in Holland, where the swans nest on them every year.

They also have them in England and Canada on the lakes. But nobody had ever put them into an estuary before and that was the challenge—how we could manage when the tide comes in.”

But when prices quoted for specialised rafts proved too costly, Conservation Volunteers Galway (<https://www.facebook.com/ConservationVolu>) stepped in and offered what they could.

“So I contacted a builder I know and he made it out of pallets locked together in a very rugged, solid frame. I worked out the calculations so that it would float and be stable enough and wouldn’t be too high or too low,” Peter explains.

If the raft floated more than half an inch above the waterline, the cygnets wouldn’t be able to get back on it if they were in the water, he says.

But if it was too low, the waves would come in and wash the nest off. “So it was a very delicate balancing act but it worked perfectly.”



(<http://claregalway.info/wp-content/uploads/2015/05/000aa708-642.jpg>)

The swans with their five remaining cygnets. Photo via RTE.ie.

Once the raft was finished, eight men couldn't physically lift it, but it had to be strong to work. So once it was pushed into the water, Peter and his team lured the swans onto the platform using food. Thankfully, the swans took the hint and there was a nest of eggs on the platform, located near Tesco in Oranmore village, within weeks.

“Then what we didn't know was if it was too exposed. The last month was pretty vicious in terms of cold weather and they were desperately trying to keep these eggs warm... And there was just a lot of bad weather thrown at them and we thought maybe it's just too exposed a location.”



(<http://claregalway.info/wp-content/uploads/2015/05/000aa707-614.jpg>)

Thanks to the manmade platform, eight out of nine eggs hatched. Sadly only five of the eight cygnets survived, but the local community has taken the long-awaited surviving cygnets to their hearts.

“It has provided a focal point to the estuary. A lot of people walk that area now and have great interest in it,” says Peter of the swans and their new family home.